



Administrator's Manual



Tables of Contents

<i>Printronix Products Information</i>	1
<i>Safety and environmental notices</i>	2
<i>Safety notices</i>	2
<i>Danger hazard level</i>	2
<i>Caution hazard level</i>	2
<i>Attention notices</i>	2
<i>Safety precautions</i>	3
<i>Electrical safety</i>	3
<i>Approved power cord and receptacle</i>	3
<i>Electrical safety and portable power strip receptacles</i>	4
<i>Connecting or disconnecting a communication port, a teleport, or an attachment connector</i>	4
<i>Servicing during an electrical storm</i>	4
<i>FFC Notes</i>	5
<i>European Union (EU) Conformity Statement</i>	5
<i>Industry Canada Compliance Statement</i>	5
<i>Statement for CISPR 22 Edition 2 Compliance</i>	5
<i>Getting to Know Your Printer</i>	6
<i>Printer Features (model type S809 and S809+)</i>	6
<i>Printer Parts</i>	7
<i>Front View</i>	7
<i>Rear View</i>	7
<i>Setting Up Your Printer</i>	8
<i>Choosing a Suitable Location</i>	8
<i>Ribbon Cartridge Installation</i>	9
<i>Power Connection</i>	13
<i>Host Computer Connection</i>	14
<i>Driver Installation</i>	15

Windows Environment	15
LAN Connection	16
Monitoring Printer & Remote Printer Configuration in LAN using a Browser	17
Remote Printer Management Utility (RPMU)	22
UNIX Environment	23
Linux 7.x & Solaris 7.x Operating Systems	25
AS/400 Environment	26
Configuring AS/400 for ASCII (TCP/IP protocol)	26
Configuring with ADDTCPIFC	26
Selecting the Display Language	29
Configuring the Printer	30
Operator Panel Presentation	30
Display Messages	30
Indicators	32
Function Keys	32
ON LINE Key	33
PROGRAM Key	33
MACRO Key	33
FONT Key	33
LF Key	33
LOAD/FF Key	34
ALTERNATE Key	34
TEAR/PITCH Key	34
PATH/PARK Key	34
Printer Setups	35
Entering the Printer Setups	35
Moving within the Printer Setups	35
Leaving the Printer Setups	35
Printer Setup Item	35
Power-On Configuration Setup	36

Entering the Power-On Configuration Setup	36
Main Structure	36
Printout of the Configuration Printer Settings	37
Emulation Options	38
Setting the Emulation Options	38
Printer Emulation	38
EPSON Character Sets	39
IBM Character sets	39
EPSON National Character sets	39
IBM National Character Sets	40
CR Code Behavior	40
LF Code Behavior	41
IBM Compressed Printing	41
Bar code mode	41
Interface	42
Interface Type Settings	42
Parallel Interface	43
Setting the Parallel Interface Parameters	44
Interface Type	44
Setting the Select-In Signal	44
Number of Data Bits	44
Input Buffer Size	45
Serial Interface	46
Setting the Serial Interface Parameters	46
Interface Type	46
Baud Rate	47
Number of Data Bits	47
Parity Check	47
Handshake Protocol	48
Connection Type	48

Input Buffer Size	48
LAN Interface	49
Setting the LAN Interface Parameters	50
IP Assignment	50
Init IP Address	50
Init Net Mask	50
ID Default Gateway	51
Init Host Name	51
Init Workgroup Name	51
Enable/Disable the SMTP Service	52
Mail Server Address	52
E-mail Address	52
Sender Address	53
Enable/Disable the LPR Service	53
Enable/Disable the FTP Service	53
Enable/Disable the TELNET Service	53
Enable/Disable the DIRIP Service	54
Enable/Disable the HTTP Service	54
Enable/Disable the SNMPD Service	54
Enable/Disable the SMBD Service	54
Functions	55
Setting the Functions Group Items	56
Enable/Disable the Buzzer	56
Paper Loading Sequence	56
Bar Code Density	56
Text Print Direction	57
Graphics Print Direction	57
Bar Codes Print Direction	57
Graphics Printing Speed Selection	57
Paper Path at Power-On	58

<i>Selection of the Language of the Display Messages</i>	58
<i>Enable/Disable Front1 Tractor Jam Sensor</i>	59
<i>Enable/Disable Front2 Tractor Jam Sensor</i>	59
<i>Adjusting the Tear-Off Position</i>	59
<i>Resetting to Factory Default Values</i>	60
<i>Program Setup</i>	61
<i>Entering the Program Setup</i>	61
<i>Main Structure</i>	61
<i>Printout of the Printer Settings</i>	62
<i>Printout of the Printer Statistics</i>	63
<i>User Macro</i>	64
<i>Selection of the User Macro</i>	64
<i>User Macro Parameters</i>	65
<i>Line Spacing</i>	66
<i>Line Spacing Lock</i>	67
<i>Page Length</i>	67
<i>Top of Form</i>	67
<i>Form Feed (FF) Command</i>	68
<i>Skip Over Perforation</i>	68
<i>Draft Print Mode Selection</i>	68
<i>Font Lock</i>	69
<i>Quality Print Mode Selection</i>	69
<i>Font Selection</i>	69
<i>DBCS Font Selection</i>	70
<i>Pitch Selection</i>	70
<i>DBCS Pitch Selection</i>	70
<i>Micro Dot Print Mode</i>	71
<i>Pitch Lock</i>	71
<i>Left Margin</i>	71
<i>Right Margin</i>	72

Zero Character Printing	72
Paper Path Selection	72
Tear-Off Mode	73
Tear Delay Mode	73
Print Impact Strength	73
Paper Perforation	74
Quiet Printing	74
Adjusting the Distance of the Print Head	74
Horizontal Character Tuning	75
Vertical Character Tuning	75
Space Compression	75
Resetting the Macro Parameters to the Factory Defaults	76
Selecting Another Macro	76
Passing over to the Power-On Configuration	76
Hexadecimal Dump	77
Storing the values	78
ANSI Emulation	79
ANSI Character Sets	79
ANSI Code Pages	79
ANSI Code Pages	79
Reset Enable	80
SI/SO Control	80
Auto Carriage Return	80
Prime on Delete	80
Control Codes in Dot Graphics	81
Vertical Expansion	81
ALT Graphics	81
8-bit Control	81
Superscript/Subscript Character Enable	82
ESC+Control Code	82

VT Code	82
Double Line Feed	82
Automatic Wrap	83
Clear Margin	83
Backup Option	83
Barcode Guard Bar Enable	84
DEC Emulation	85
G0 Character Set	85
User Preference Supplemental Character Set	85
Autowrap	86
Pitch Selection	86
Line Spacing	87
How to Select the Paper Path	88
How to Use the Tear-Off Function	88
Selection of the Paper Size	88
Adjusting the Tear-Off Position	89
Selection of the Tear-Off Mode	89
How to Lock/Unlock the Printer Setups	91
How to Handle the Paper Parking	92
Paper Paths	96
Paper Handling	96
Paper Specifications	97
Fanfold Paper	97
Fanfold Paper Loading	97
Loading Paper Using the Front1 Push Tractor	97
Printing a Configuration Sheet	100
Printer Maintenance and Troubleshooting	101
Cleaning the Printer	101
Cleaning inside the printer	101
Cleaning the outside covers	101

Replacing the Ribbon Cartridge	102
Printing the Self Test	103
Error Handling	104
Error Message Description	104
Problems List Index	106
Forms problems	106
Print quality and ribbon problems	107
Configuration problems	108
Miscellaneous problems	108
Clearing Forms Jams	109
Options	110
The double byte Controller Board (only for 809 DBCS)	110
Installing the Controller Board	110
Handling the Controller Board	110
Replacing the Controller Board	110
The Front2 Push Tractor	112
The 6 pin Front2 Push Tractor is available for the S809 printer.	112
Installing the Front2 Push Tractor	112
Removing the Front2 Push Tractor	113
Loading Paper Using the Front2 Push Tractor (option)	114
Loading Paper Using the Front1 Push Tractor when the Front2 Push Tractor (Option) is Installed	116
The Printer Pedestal	117
Printer Specifications	118
Printing Characteristics	118
Customer Support	122
Printronix Customer Support Center	122
Printronix Supplies Department	123
Corporate Offices	124

Revision Record

260066-001A	First Issue	October 2017
260066-002A	Introduction of S809+ model (changes on pages 1, 7, 14, 119)	September 2019

Printronix Products Information

Thanks for choosing the **Printronix S809** printer model.

Your printer is a reliable working equipment that will be very useful in your daily job.

Our printers have been designed to be compact and respectful of the work environment.

They offer a wide range of features and multiple functions that confirm the high technological level reached by the Printronix brand.

To maintain these printing performances unchanged in the long run, Printronix has developed specific Printronix branded consumables for each printer type (for example: ribbon cartridges for dot matrix printers) that assure an excellent operation with high printing quality level reliability.

Printronix recommends to use only its original Printronix branded consumables with original packaging (identified by its holographic label). In this way, a proper use of the printer at quality level stated in the product characteristics can be assured. All typical usage problems related to not certified consumables may be avoided, such as an overall quality print level degradation and, often, the reduction of the product life due to the fact that the proper working conditions for the print heads and other printer parts are not assured.

Moreover, Printronix does not only certify its consumables in terms of working conditions but also carefully controls their compliance with the international standard rules concerning:

- no cancerous materials;
- no flammability of the plastic materials;
- other standards

Printronix advises the customers not to use products for which the compliance to this safety rules are not warranted.

Finally seek your dealer or contact a Printronix office and be sure that you are provided Genuine Printronix branded consumables.

Safety and environmental notices

Safety notices

There are two levels of safety notices: Danger and Cautions.

Danger hazard level

The word Danger indicates the presence of a hazard that has the potential of causing death or serious personal injury.

Most DANGER notices are numbered <1-1>, <1-2>, and so forth where they appear in the text of this manual.

Example of a Danger notice:



DANGER

<1-10> Hazardous voltages are present. Do not touch the pins or sockets of the power receptacle

Caution hazard level

The word Caution indicates the presence of a hazard that has the potential of causing moderate or minor personal injury.

Most CAUTION notices are numbered <2-1>, <2-2>, and so forth where they appear in the text of this manual.

Example of a Caution notice:



CAUTION:

<2-22> Carefully follow all cleaning instructions, using only the materials and solutions recommended.

Attention notices

The word Attention calls attention to the possibility of damage to a program, device, system, or data.

Attention notices are not numbered.

Examples of an Attention notice:

Attention: The above openings must always be protected with their covers. Do not touch inside and do not insert any object into these openings or into the gears.

Safety precautions

Never remove any printer cover except to install a printer accessory as expressly described in this manual.

The following areas of the printer should be covered for safety reasons:

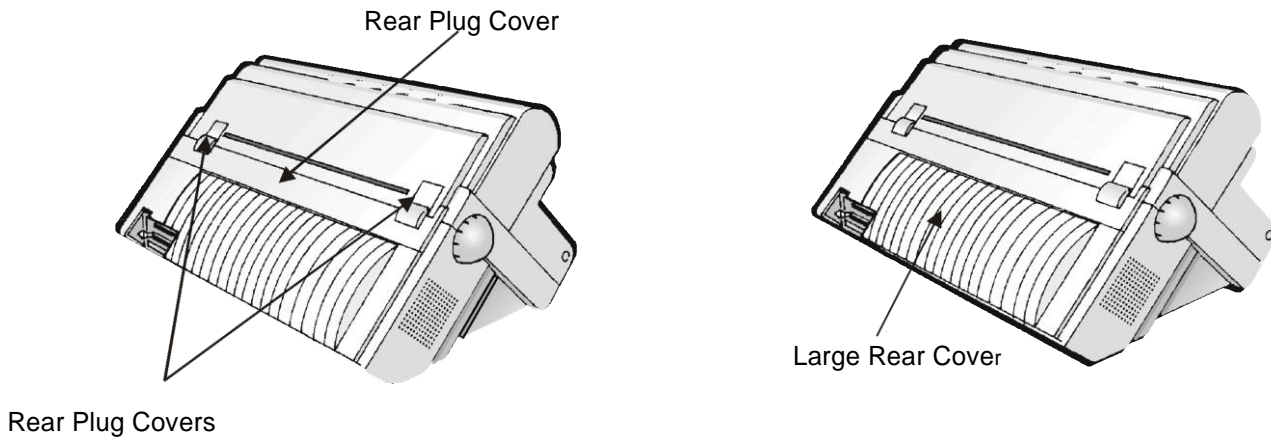

**The above opening must always be protected with their cover.
Do not touch inside and do not insert any object into these openings or into the gears.**

Attention: The above openings must always be protected with their covers. Do not touch inside and do not insert any object into these openings or into the gears.

Electrical safety

This printer is inspected and listed by recognized national testing laboratories, such as Underwriters Laboratories, Inc. (UL) in the U.S.A. and Canadian Standards Association (CSA) in Canada. Listing of a product by a national testing laboratory indicates that the product is designed and manufactured in accordance with national requirements intended to minimize safety hazards. This equipment meets a very high standard of safety in design and manufacture. Remember, however, that this product operates under conditions of high electrical potentials and heat generation, both of which are functionally necessary.

Because the paper used in the printer can burn, you should take normal precautions to prevent fire. These precautions include common-sense measures, such as keeping potentially combustible materials (for example, curtains and chemicals) away from the printer, providing adequate ventilation and cooling, limiting unattended operation, and having trained personnel available and assigned to the printer.

Approved power cord and receptacle



DANGER

<1-11> Your country may require an approved power cord and plug.

Ensure that you have the correct power cord and plug. Use this cord and plug only with an approved, correctly-installed power receptacle.

Electrical safety and portable power strip receptacles

Extension cords



DANGER

DANGER<1-1> Do not use an extension power-cord.

The customer must supply the correct electrical outlet which must meet the requirements stated under "Printer Specifications" in the Administrator's Manual.

Portable power strip receptacles (temporary power taps)

Portable power strip receptacles (referred to as "temporary power taps" by the National Electrical Code) may be used if they are fully approved in the customer's geographic location. It is the customer's responsibility to supply a fully approved "temporary power tap", if one is to be used.

Connecting or disconnecting a communication port, a teleport, or an attachment connector



DANGER

<1-14> Switch off printer power and unplug the printer power cord before connecting or disconnecting a communication port, a teleport, or other attachment connector.

Servicing during an electrical storm



DANGER

<1-13> Do not connect or disconnect a communication port, a teleport, or any other connector during an electrical storm.

FFC Notes

This equipment has been tested and found to comply with the limits for a Class A digital device, pursuant to Part 15 of the FCC Rules. These limits are designed to provide reasonable protection against harmful interference when the equipment is operated in a commercial environment. This equipment generates, uses, and can radiate radio frequency energy and, if not installed and used in accordance with the instruction manual, may cause harmful interference to radio communications. Operation of this equipment in a residential area is likely to cause harmful interference in which case the user will be required to correct the interference at his own expense. Properly shielded and grounded cables and connectors must be used in order to meet FCC emission limits. Printronix is not responsible for any radio or television interference caused by using other than recommended cables and connectors or by unauthorized changes or modifications to this equipment. Unauthorized changes or modifications could void the user's authority to operate the equipment. This device complies with Part 15 of the FCC Rules. Operation is subject to the following two conditions: (1) this device may not cause harmful interference, and (2) this device must accept any interference received, including interference that may cause undesired operation.

European Union (EU) Conformity Statement

Printronix declares that this product is in compliance with the essential requirements and other relevant provisions of Directive 2014/35/EU (LVD Standard) and 2014/30/EU (EMC Standard).

Per the applicable requirements of EU directive 2006/42/EC ("machines") sound pressure of the above product (measured according to EN ISO 7779-2001) does not exceed 70dBA.

This product has been tested and found to comply with the limits for Class A Information Technology Equipment according to European standard EN 55032. The limits for Class A equipment were derived for commercial and industrial environments to provide reasonable protection against interference with licensed communication devices. **Important** This is a Class A product. In a domestic environment this product may cause radio interference in which case the user may be required to take adequate measures.

Properly shielded and grounded cables and connectors must be used in order to reduce the potential for causing interference to radio and TV communications and to other electrical or electronic equipment. Printronix cannot accept responsibility for any interference caused by using other than recommended cables and connectors.

Industry Canada Compliance Statement

This Class A digital apparatus complies with Canadian ICES-003.

Cet appareil numérique de la classe A est conform à la norme NMB-003 du Canada.

Statement for CISPR 22 Edition 2 Compliance

Attention: This is a Class A product. In a domestic environment this product may cause radio interference in which case the user may be required to take adequate measures.

Getting to Know Your Printer

Printer Features (model type S809 and S809+)

- 24 Needle Print Head
- 136 columns @10 cpi
- High speed Draft printing at 900 cps, Draft printing at 800 cps, LQ printing at 133 cps
- IBM Proprinter XL24/XL24 AGM, Personal Printer 2391+, EPSON LQ Series, ANSI X3.64 and DEC PPL2 emulations
- Base paper handling configuration: Front1 push path (Fanfold with 6 pins sprockets and paper jam sensor detection)
- Multiple copies (1 original and 7 copies)
- Automatic paper path selection
- Easy operability via operator panel setup and S/W commands
- Usage of all specific features by means of the Specific Software Driver which is applicable to the most popular S/W Packages
- Plug & Play capability for Windows 95/98/2000/XP/NT4.0/Millennium ®/Vista/Win7(32 & 64bit), Windows8, Windows10
- Single controller with four interfaces: Ethernet 10/100 Base-T interface option, Bi-directional IEEE 1284 parallel interface, serial RS-232/C interface and USB interface
- Optional Front2push path (Fanfold with 6 pins sprockets and paper jam sensor detection)
- Optional printer pedestal
- The Epson LQ1600K emulation is available with the Double Byte Character Set - feature installed in specific controller with interfaces as well as the standard controller.

Printer Parts

Front View

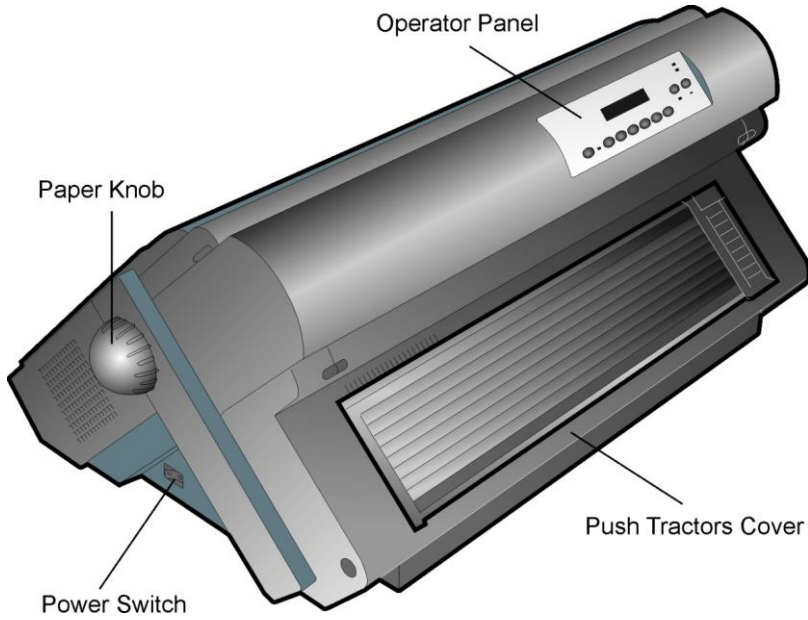

Rear View

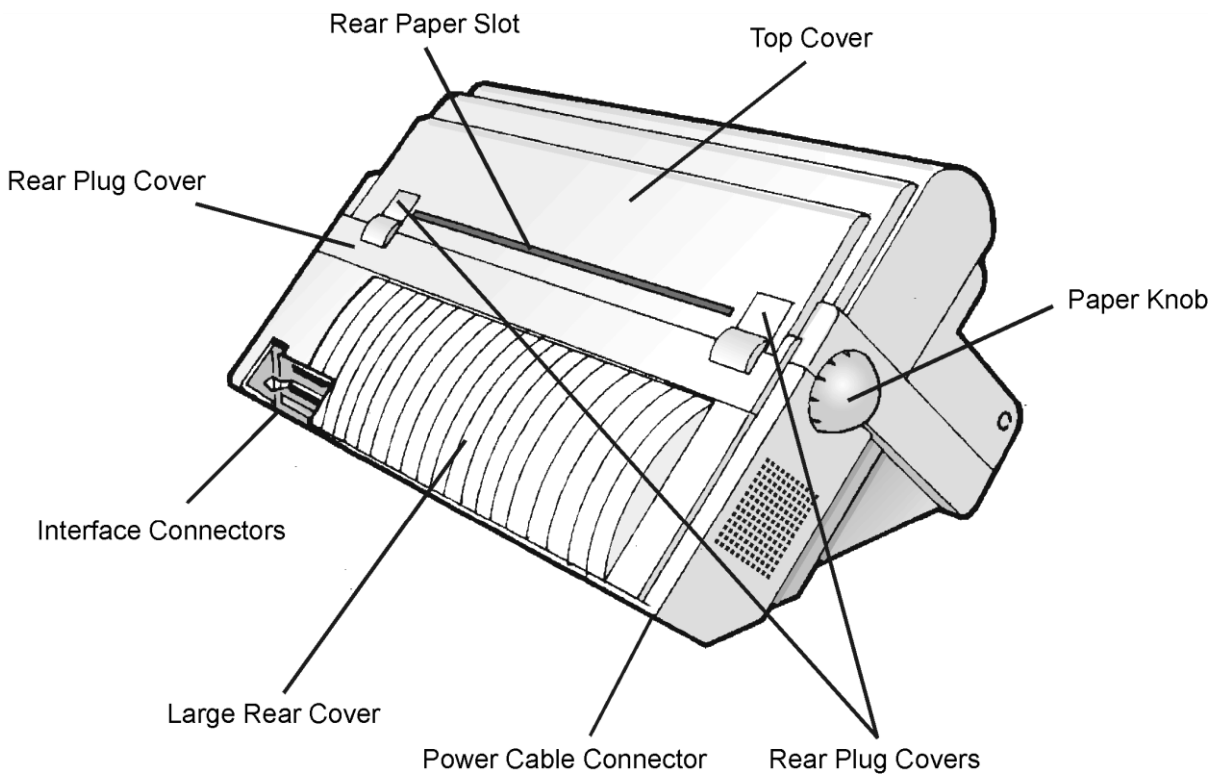

Setting Up Your Printer

Choosing a Suitable Location



CAUTION:

The S809 printer weighs 21 kg (46 lbs). Two persons are required to lift it.

Consider the following points when you choose the location for your printer:

- The distance between the printer and the host computer must not exceed the length of the interface cable;
- The location must be sturdy, horizontal and stable;
- Your printer must not be exposed to direct sunlight, extreme heat, cold, dust or humidity (see "Printer Specifications " later);
- The power outlet must be compatible with the plug of the printer's power cord.
- There must be sufficient clearances on all sides for easy operation.
- The required space is shown in the figure:



Ribbon Cartridge Installation

Make sure that you are using only Genuine Printronix consumables

1. Make sure that the printer is turned off.
2. Find the ribbon cartridge among the accessories

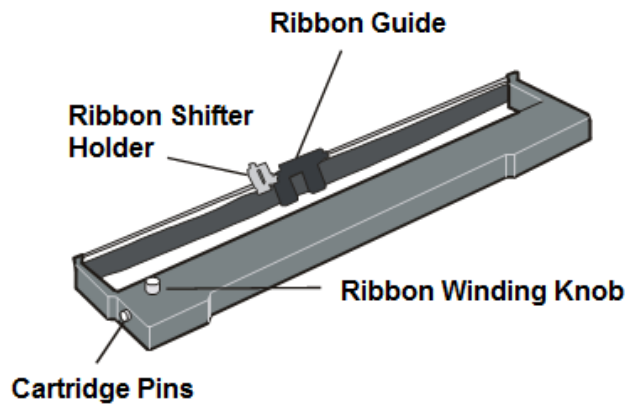

3. Turn the printer on and wait for printer initialization.
4. With the printer powered on, enter the OFF LINE status pressing the ON-LINE Key and then checking ON-LINE indicator unlit.
5. Open the top cover using the small handles on either side of the top cover

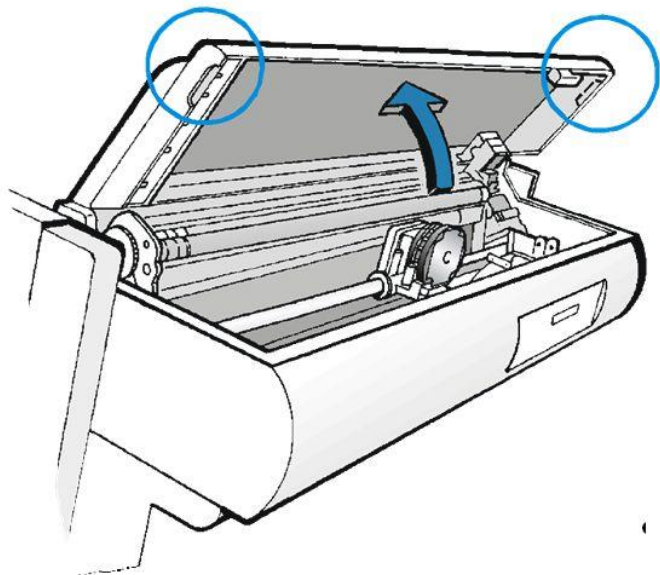

6. Move the print carriage in the middle of the area to prepare it for ribbon cartridge installation

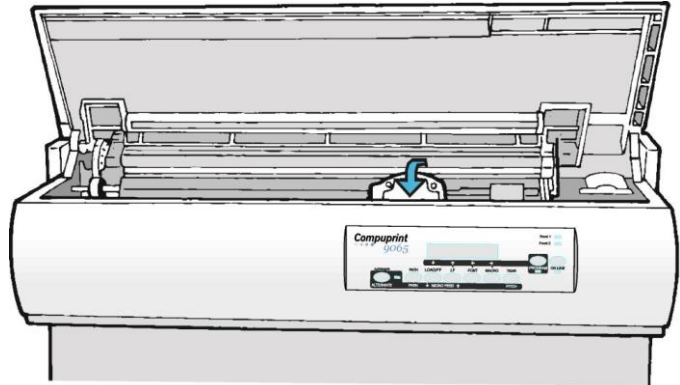

7. Before installing the ribbon cartridge turn the ribbon-winding knob in the arrow direction (located on the cartridge) to take up slack in the ribbon

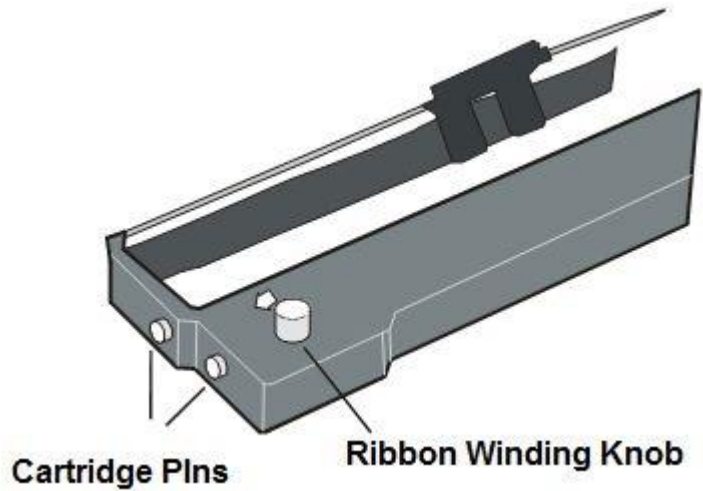

To avoid damage to the ribbon, do not turn the winding knob in the wrong direction

- a. Align the right and left cartridge pins with the printer locking points.

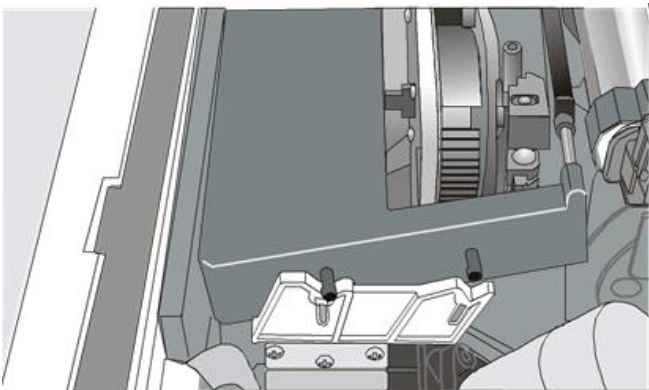

Black cartridge when the ribbon shifter option is not installed

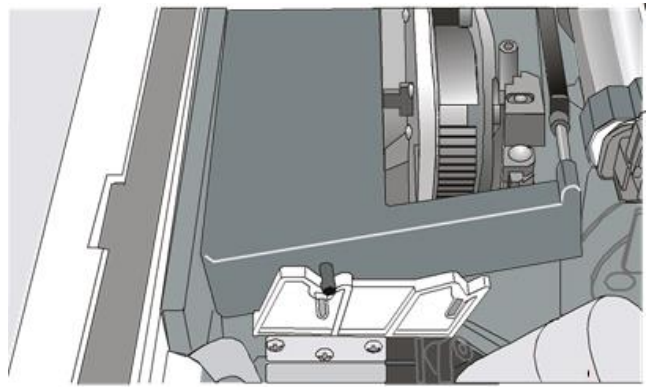

Black "Long Life" cartridge when the ribbon shifter option is installed

Slide and insert the ribbon guide between the print head and the ribbon guide mask holding it perpendicular to the print head.

Make sure that the ribbon is inserted correctly between the print head and the print head mask.

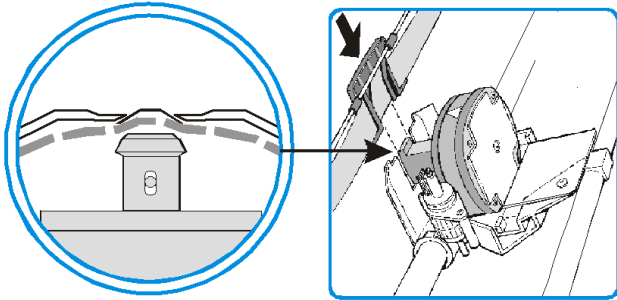

OK

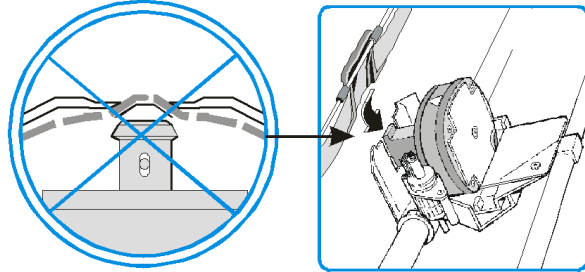

NO

8. If the shifter kit option is installed on your printer, insert the shifter holder onto the ribbon shifter as shown in this figure.

9. Insert the shifter holder onto the ribbon shifter as shown in the following figure.

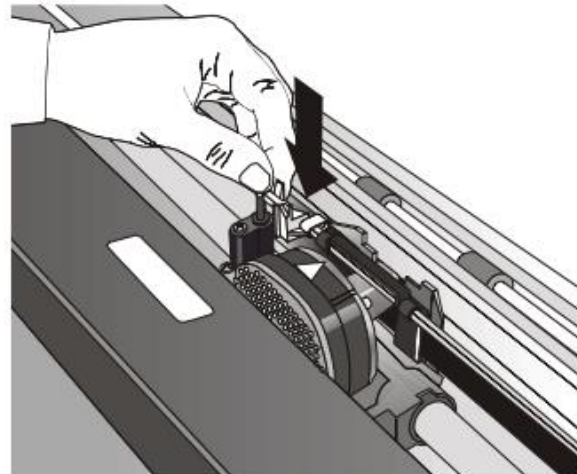
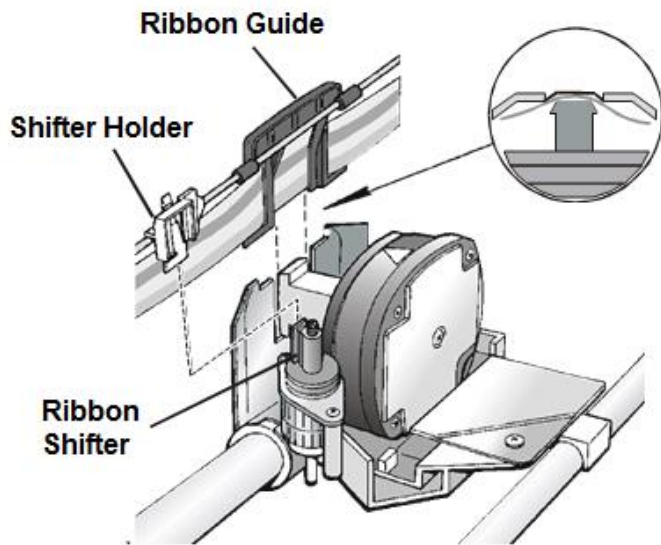

10. Turn the ribbon-winding knob in the arrow direction (located on the cartridge) to take up slack in the ribbon.

10. Push the cartridge down gently until it clips into place at locking points

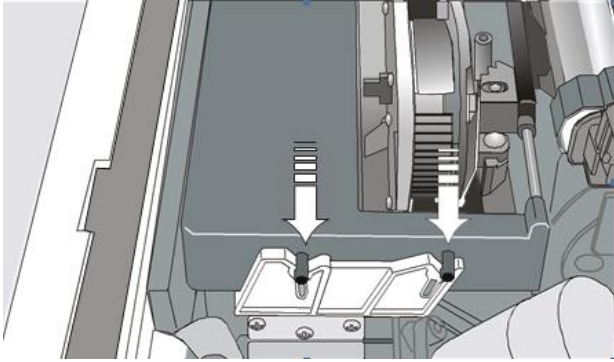

Black cartridge when the ribbon shifter option is not installed

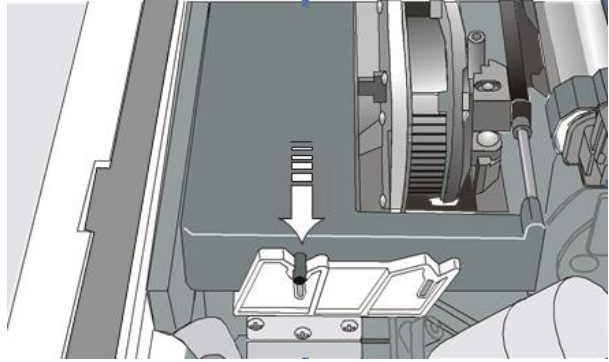

Black "Long Life" cartridge when the ribbon shifter option is installed

11. Turn the ribbon-winding knob again in the direction of the arrow to take up slack in the ribbon.
 12. To ensure that the ribbon guide runs freely along the ribbon, manually move the print carriage horizontally.
- If the used ribbon cartridge needs to be replaced, see "Replacing The Ribbon Cartridge", later in this manual.

Power Connection



DANGER

<1-11> Your country may require an approved power cord and plug. Ensure that you have the correct power cord and plug. Use this cord and plug only with an approved, correctly-installed power receptacle.

1. Make sure the power outlet is near the printer location and easily accessible.
2. Make sure that the power switch is in *O* position (OFF).

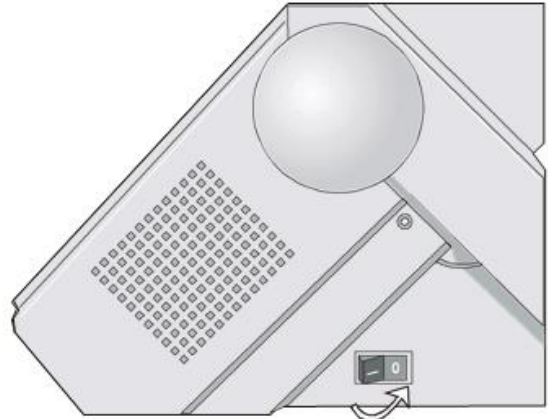

3. Insert the power cable plug into the printer connector and the other power cable end into a convenient 10A protected outlet for European market or 20A protected outlet for US Market (the figure shows the European version).

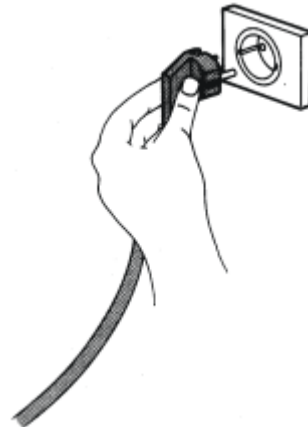
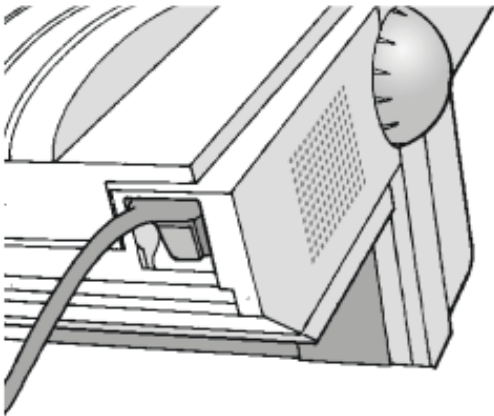

4. If you need to turn the printer on, press the power switch in the *I* position (ON).

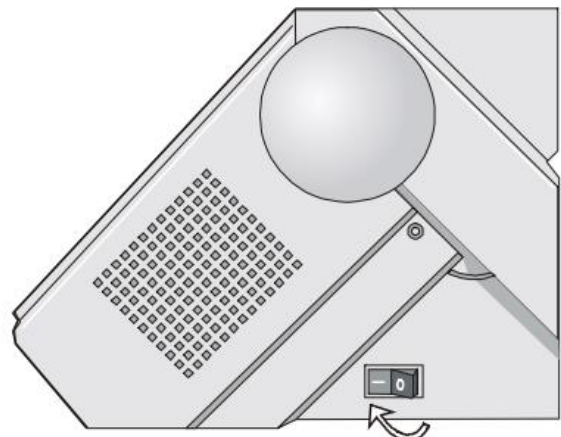

Host Computer Connection

The S809 printer can be connected to your host computer via different available interfaces on a single controller. Two different controllers are available:

- SBCS (single byte) controller
- DBCS (double byte) controller



DANGER

<1-14> Switch off printer power and unplug the printer power cord before connecting or disconnecting a communication port, a teleport, or other attachment connector.

The controller provides the following four interfaces:

- A bidirectional IEEE1284 parallel interface
- A RS-232C serial interface
- An USB interface.
- An Ethernet LAN interface.

The interface connectors are located on the rear of the printer.

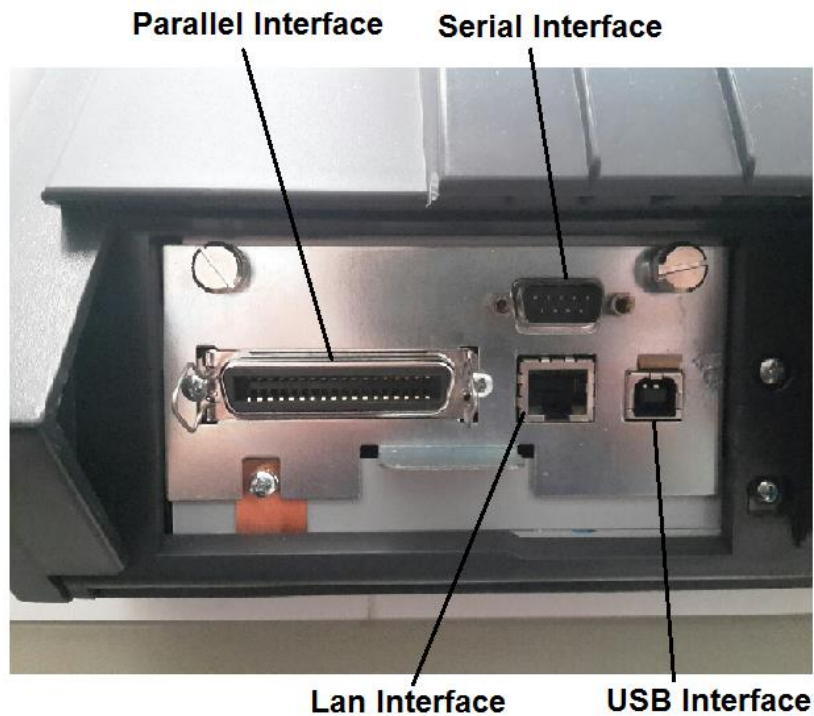

Driver Installation

Windows Environment

At this point it is necessary to configure your printer for your Operating System. The installation procedures depend upon the host environment.

**The printer drivers of all current Printronix printers can be found
<http://www.Printronix.com>**

Starting from WINDOWS 95/98/2000/XP/NT4.0/Millennium®/Vista/Win7/Win8/Win10 environments the printer supports the Plug & Play feature.

LAN Connection

To work under LAN (Local Area Network) it is mandatory to set the LAN Interface Through the Printer Operator Panel to match the network setting. See later on the specific LAN configuration chapter. Contact your system administrator for the correct values.

In the Local Area Network printing environment, the PCs can share a printer, that is, different users can use the same printer.

Software installation must be carried out on every PC requiring access to the Printronix printer.

For the communication between the PCs and the Printronix printer is necessary that the same LAN protocol is used for all connected devices: the TCP/IP or the NetBEUI protocol in a Windows environment.

Monitoring Printer & Remote Printer Configuration in LAN using a Browser

The LAN interface of the printer has a built-in web pages which can be used for monitoring the status of the network printer and for the remote configuration.

Following procedure describes the use of an Internet Browser (i.e.: IE, Mozilla, Chrome, etc.)

To browse the printer Home web page, enter the IP Address as web page address.

The IP Address must correspond with the IP Address set in the INIT IP ADDRESS parameter of the LAN INTERFACE item

Home Page

The Printer Home Web Page screen appears as the mask on the right:

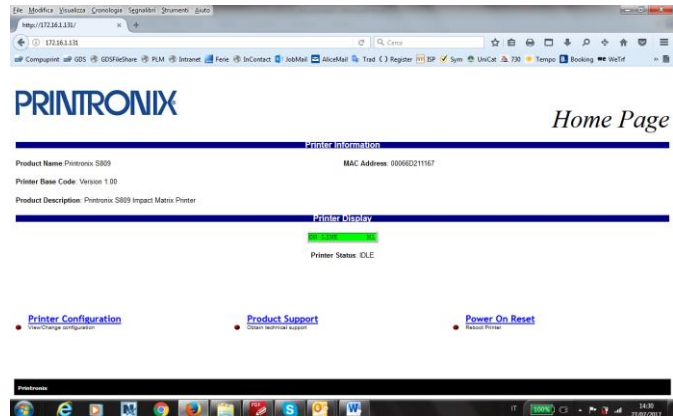

This Printer Home Web Page shows the current status of the printer :

Product Name:Printronix S809

MAC Address: xxxxxxxxxxxx

Printer Base Code: Version 1.00

Product Description: Printronix S809Impact Matrix Printer

And can activates following types of information about the printer:

Printer Configuration: printer setting that you can configure by remote control.

Product support: reference to contact Printronix support

Power On Reset: feature to reboot the printer

When click on Printer Configuration the System Page is opened:

It is possible to choose:

- Loading the default factory setting parameters overwriting the current ones for all setup pages (All, Macrox, Configuration)
- Setting the default Macro at power on
- Setting the security password
- Select one of the different webpages (Home, System, Config, Interface, Lan, Macro#) described hereafter.

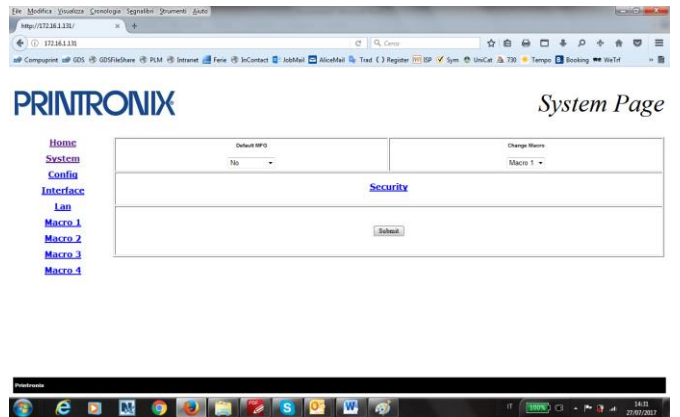

System Page

In the System Page click on Security Setting button. The first time the following screen appears:

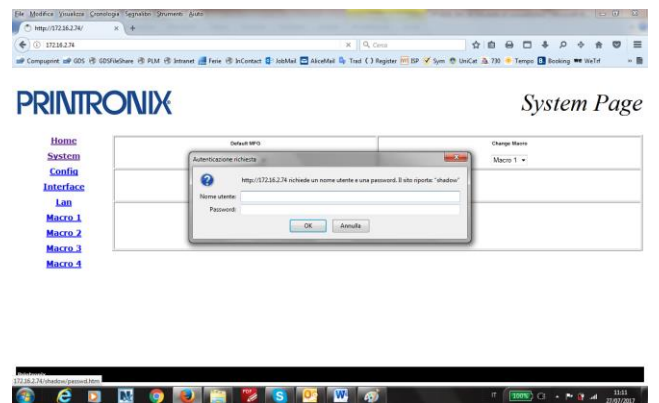

Type root for User Name
Type root for password

Security Page

It is now possible to indicate a new password to protect the setting

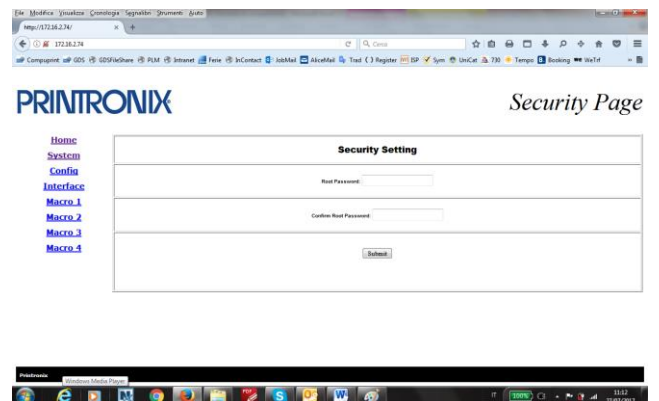

Security Page

The following screen appears

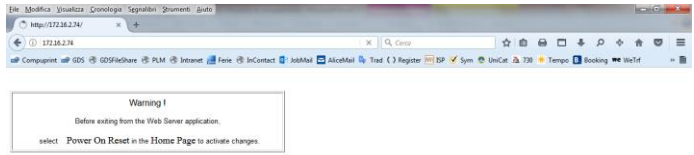

REMARK

Remind you that it is necessary to select Power on Reset button to go to Reboot Page and save the changes.

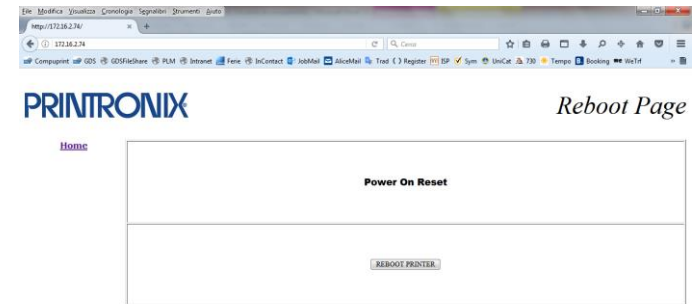

Screen after Reboot Printer action

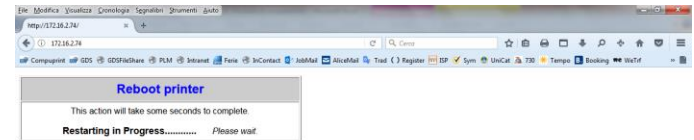

Printer Configuration

Config Options Page

To obtain the Printer Configuration information tables, click on the respective left button. This page contains a series of tables with the corresponding printer set-up. For a detailed description of each parameters and values refer to the Configuration chapter later on in this manual. This is the Configuration Options Page

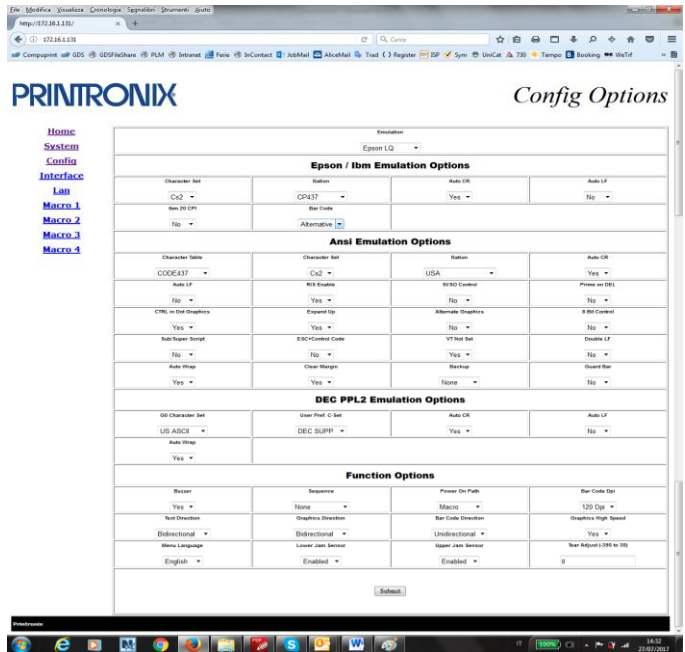

Interface Options Page

This is the Interface Options Page

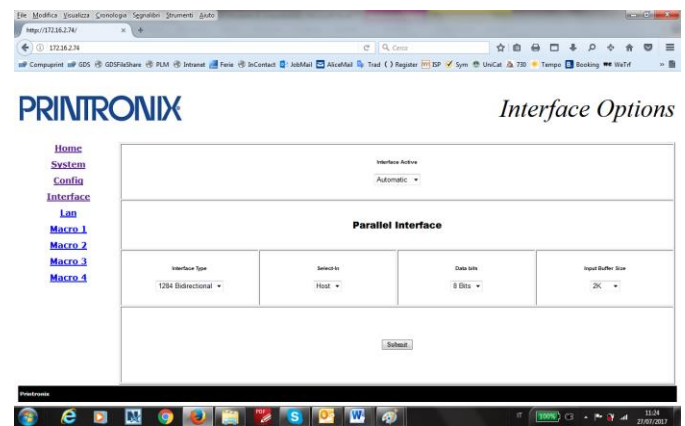

Lan Settings Page

This is the Lan Setting Page

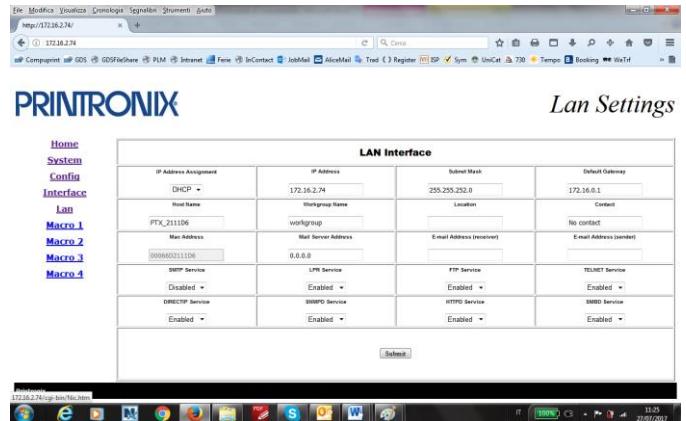

User Macro x Page

This is the User Macro# Page



You can now choose the network printer configuration. When the parameters are set as necessary, click on the Submit button at the end of the table. If a password has already been set in the Security item, to enter the remote printer configuration mode you need to type the network password

Support

This is the Printronix Support Page

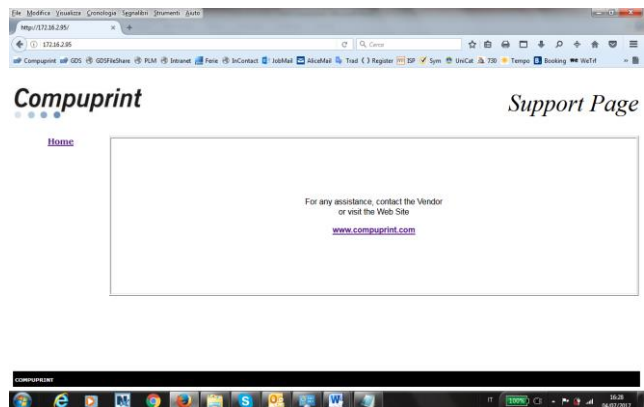

Remote Printer Management Utility (RPMU)

The Remote Printer Management Utility (RPMU) is a software tool for network administrators that allows the configuration and control of Printronix Serial Dot Matrix and Transactional Dot Matrix Printers remotely connected to the Ethernet LAN. With this tool the installed printers may be controlled, configured and organized easily. Detailed information can be found in the RPMU Administrator's Manual at Printronix.com.

The main features are the following:

- Device Discovery: searches for the devices within a range of IP addresses.
- Printer Organization: the printers connected to the network can be organized into logical groups in a hierarchically structured tree.
- Printer Status Report: checks the printer's status and reports alarms
- Printer Configuration: the remotely connected printers may be configured as needed from the administrator's workstation.
- Firmware Updating: provides a firmware downloading function to upgrade both the base and the LAN card firmware.
- Remote Operator Panel Management: provides a virtual operator panel for the remotely connected printer at the administrator's workstation that allows to perform all functions normally achieved pressing the operator panel keys.

The RPMU also provides the basic status management for third-party printers compliant to the standard MIB objects. The RPMU is a Java based application and can be run on any platform supporting the Java Run Time Environment version 6 or newer.

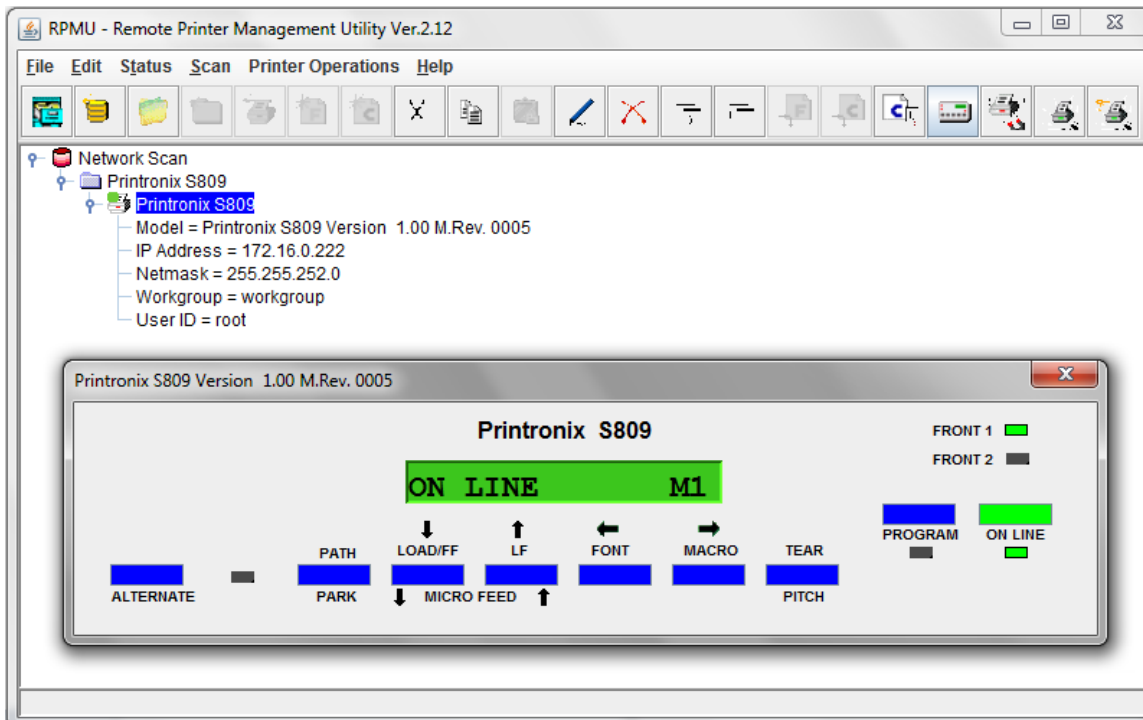

4. Enter the *Logical Port Name*.

The Logical Port Name is "prt1".

```

Command Prompt - telnet loki
-----
Printer installation wizard < cmpinstall 1.0.0 Beta >
DATE : mar mag 22 10:17:15 CEST 2001
-----
Remote Host Name <Ex. 192.168.0.100 > -> 10.0.252.201
Logical Port <Ex. cnp1p> -> prt1_

```

5. Enter the Print Server Name.

The printer server name is "ps1".

```

Command Prompt - telnet loki
-----
Printer installation wizard < cmpinstall 1.0.0 Beta >
DATE : mar mag 22 10:17:15 CEST 2001
-----
Remote Host Name <Ex. 192.168.0.100 > -> 10.0.252.201
Logical Port <Ex. cnp1p> -> prt1
Print Server Name <Ex. lp>-> ps1

```

6. If this configuration is ok , enter "y" to confirm.

```

Command Prompt - telnet loki
-----
Printer installation wizard < cmpinstall 1.0.0 Beta >
DATE : mar mag 22 10:17:15 CEST 2001
-----
Host information :
- Type : Linux
- Name : loki
-----
Queue information :
- Name : ps1
- Port : prt1
- Remote : 10.0.252.201
-----
Config directory :
- Spool : /var/spool/lpd/ps1
- Printcap : /etc/printcap
-----
Choiche <Y/N> -> y

```

The installation is now complete. If you want to print the test file, enter the *lpr -Pps1 test* command.

Linux 7.x & Solaris 7.x Operating Systems

To configure the printer for the Linux 7.x and Solaris 7.x operating systems, follow the corresponding procedure described below:

Configuring a Remote Printer for the Red Hot Linux 7.x Operating System

1. Open the `/etc/hosts` file as *root user* in a Terminal windows.
2. Add the *IP address* and the *Printer Name* information.
Here is an example of an `/etc/hosts` file:

Ip-address	Printer-name
10.0.128.220.1	prt1
10.0.128.220.2	prt2
3. Type `"printconf-gui&"` from a prompt
4. Click *New* button. You are asked to enter a *queue name* for the printer. Type the *queue name* you want.
5. Then select `"Type of queue"`. Select *Unix Printer (lpd queue)* in the `"Queue type"` box.
6. Insert the *printer name* used in `/etc/hosts` file (i.e. *prt1* or *prt2*) in the `"Server"` or `"Remote Hosts"` box.
7. Insert the *local spool directory* (where the print jobs for the Unix computer are to be placed) in the `"Queue"` or `"Spool Directory"` box.
8. Select *text only* in the `"Printer Driver"` box. Set up the configuration you want and then click *OK* button.
9. Click *File ->Save Changes* in the `"printconf-gui"` window.
10. Restart *lpd* to have (let) the printer daemon receive the new printer entry.

If the print job is rejected when it is sent to test the printer, ask the remote computer's administrator to check permission in the `"/etc/lpd.perms"` file

Configuring a Remote Printer for the Solaris 7.x Operating System

1. Open the `/etc/hosts` file as *root user* in a Terminal windows.
2. Add the *IP address* and the *Printer Name* information

Here is an example of an `/etc/hosts` file:

Ip-address	printer-name
10.0.128.220.3	prt1
10.0.128.220.4	prt2

3. Type `"admintool&"` in a Terminal windows.
4. Select *Browse* button and then *Printers*.
5. Select *Edit->Add->Access to Print* in the `"Admintool Printer Menu"`.
6. Insert the printer name you want in the `"Printer Name"` box.
7. Insert the printer name used in `/etc/hosts` file (i.e. *prt1* or *prt2*) in the `"Printer Server"` box.
8. Click *Apply* and then *OK* button.

Now you are ready to use the printer.

AS/400 Environment

Configuring AS/400 for ASCII (TCP/IP protocol) Configuring with ADDTCPIFC

ADDTCPIFC is used to add a TCP/IP interface to AS/400. This step configures the AS/400 for connection to a TCP/IP

1. At the AS/400 command line, enter the following command:

```
ADDTCPIFC
INTNETADR('127.000.000.000')LIND(ETHLAN)
SUBNETMASK ('255.255.254.000')
```

This screen should look like the following one:

```
Internet address      127.000.000.000.
.....:
Subnet Mask          255.255.254.000.
.....:
Line                 ETHLINE
.....:
```

To specify the IP Address and the Subnet Mask, see the values set in the LAN Configuration parameters.

Configuring a Router Definition with ADDTCP RTE

If necessary, use the ADDTCP RTE command to create a route definition.

This is required if the printer is somewhere other than a local segment.

Configuring a Local Domain and Host Name

The AS/400 print commands require a local name and host name. If you have already configured LAN attached TCP/IP printers on the AS/400 system, you will have a local domain name and hostname configured on the system. To configure the local domain, you will run the CFGTCO command.

Configuring a TCP/IP Host Table Entry

Although it is optional to create a TCP/IP host table entry, it is suggested that you take this step.

Add the AS/400 name and the LAN IP address to the "Host Table Entries".

Configuring AS/400 for Printing

The procedure for configuring an AS/400 for printing requires that you:

1. Setup the printing capability
2. Verify the setup with a print job

In order to accomplish this configuration, you need the following information:

- a. Remote Printer Queue Name. Set for any of 'pr1' through 'pr4'.

The Remote Printer Queue name must be all lower case.

- b) IP Address

See the IP Address value set in the parameter of the LAN INTERFACE item in the Power-On Configuration setup.

Setting up Printing for ASCII Files

The next step in configuring the AS/400 is to setup the remote printing capability.

There are two ways to do this:

1. You can specify the LPR parameters Manually each time you send a file to the printer
2. Use remote writer and a remote output queue for automatic printing to the printer

To Use LPR Manually

1. Start TCP/IP, if it not already running, by entering the STRTCP command
2. At the AS/400 command line, enter 'LPR'.
3. The following example shows only the parameters you need to specify:

Remote System	RMTSYS	INTNETADR
Printer Queue	RTQ	d1prn
Destination Type	DESTTYP	OTHER
Transform SCS to ASCII	TRANSFORM	YES
Manufacturer Type and Model	MFRTYPMDL	IBM6400EP
Internet Address	INTNETADR	127.000.000.000

where:

- Remote System: enter the host name of your printer or INTNETADR, which then prompts you to specify the IP address of your printer.
- Printer Queue: set to "pr1" through "pr4". The remote printer queue name must be all lower case, entered in single quotes.
- Destination Type: specify "OTHER" for the DESTTYP parameter.
- Transform: specify "YES".
- Manufacturer Type and Model: select a manufacturer type and model. Select "IBM6400EP" for Epson emulation or "IBM6400" or "IBM42023" for IBM Proprinter.
- Internet Address: specify the IP address of the printer.

To Create an Automatic Remote Output Queue

1. From the AS/400 command line, enter CRTOUTQ.
2. The following example shows only the parameters you need to specify:

Output Queue	OUTQ	USERNAME
Remote system	RMTSYS	INTNETADR
Remote printer queue	RMTprtQ	d1prn
Writer to Autostart	AUTOSRTWTR	1
Connection type	CNNTYP	IP
Destination type	DESTTYP	XAUTOQXAIX
Transform	TRANSFORM	YES
Manufacturer type	MFRTYPMDL	IBM6400EP
Internet Address	INTNETADR	127.000.000

where:

- Output queue: enter the name of the AS/400 output queue.
- Remote System: enter the host name of your printer or INTNETADR, which then prompts you to specify the IP address of your printer.
- Remote Printer Queue: set to "pr1" through "pr4". The remote printer queue name must be all lower case, entered in single quotes.
- Writer to Autostart: set the value to "1".
- Connection Type: specify this value as "IP".
- Destination Type: specify "XAUTOQXAIX".
- Transform: specify "YES".
- Manufacturer Type: select a manufacturer type and model. Select "IBM6400EP" for Epson emulation or "IBM6400PR" or "IBM42023" for IBM Proprinter.
- Internet Address: specify the IP address of the printer.

Selecting the Display Language

The display messages for this printer can be displayed in five different languages: English (Default), French, German, Italian and Spanish. To select the language, that you prefer, proceed as follows:

1. Press the PROGRAM key and keep it pressed while powering on the printer until the following message will be displayed:

RELEASE KEYS

2. When you release the PROGRAM key, the following messages will be displayed

STARTING UP

then

S809 Rel. x.yz

then

PRINT OUT? NO

3. Press the ↓ key to enter the setup. The first setup item is displayed

EMUL. OPTIONS

4. Press the ↓ key until the language first level function is displayed:

FUNCTIONS

5. Press the → key to pass to the second level functions

BUZZER YES

6. Press the ↓ key until the setup language is displayed

MENU ENGLISH

7. Press the → key to scroll the setup languages. When the desired language is displayed, press the PROGRAM key to select it. The printer exits the setup. From now on the display messages appear in the selected language.

Configuring the Printer

Operator Panel Presentation

The operator panel enables you to perform many of the printer functions including paper path selections, font selection and the printer setup.

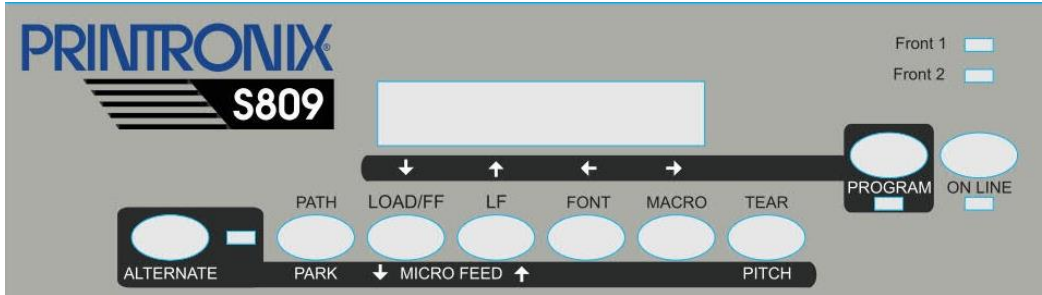

The operator panel consists of:

- A 16 character display (Liquid Crystal Display)
- Five led indicators
- Nine function keys

Display Messages

The printer display is used to indicate the printer status or to request an user intervention. When the printer is in Ready state, the display gives the following information:

- when paper is already loaded and the printer is off line (ON LINE indicator unlit):
- when paper is already loaded and the printer is on line (ON LINE indicator lit):

OFF LINE M1
 Printer Status Current Macro

ON LINE M1
 Printer Status Current Macro

Where:

OFF LINE	Indicates the printer status
ON LINE	
M1, M2, ME, M4, M5, M6, M7, M8	Indicate which of the four (or eight) User Macros is currently used. The N° depending by the Firmware level installed.

- when there is no paper loaded and the printer is off line (ON LINE indicator unlit):
- when there is no paper loaded and the printer is on line (ON LINE indicator lit):

LOAD FRONT1
 Current Paper Path

ON LINE M1
 Printer Status Current Macro

Where:

LOAD FRONT1	Indicates that the currently selected paper path is out of paper.
LOAD FRONT2	The messages are displayed only for the available paper paths, according to the installed devices.
OFF LINE	Indicates the printer status
ON LINE	
M1, M2, ME, M4, M5, M6, M7, M8	Indicate which of the four (or eight) User Macros is currently used. The N° depending by the Firmware level installed.





The following messages appear to indicate other printer conditions or user intervention requests.

The list is in alphabetical order.

MESSAGE	DESCRIPTION
ALTERNATE	This message appears to indicate that the Alternate functions of the operator panel keys have been selected pressing the ALTERNATE key.
BUSY M1	This message appears to indicate that the printer is printing. It is busy
COVER OPEN CLOSE COVER	When the printer cover is not closed correctly, the buzzer sounds and the display shows alternately these two messages. Close the printer cover
INITIALIZING LAN	This message is displayed when the LAN is reset (only if the LAN interface is present)
INVALID KEY	This message is displayed if you push a key that is not allowed in the current printer status
LOAD FRONT1 LOAD FRON2	These messages are displayed when the corresponding paper path is out of paper. The printer displays only the messages related to the installed devices
LOCKED MENU	When the access to the Printer Setups has been locked at the power on, the printer displays this message
MACRO CHANGING	The macro has been changed and the printer is updating the settings
MICRO FEED DOWN	The paper is fed in microsteps downwards when pressing the ↓ arrow key
MICRON FEED UP	The paper is fed in microsteps upwards when pressing the ↑ arrow key
OPER.INTERRUPTED	This message is displayed if the ALTERNATE key has been pressed to interrupt a park procedure
PARKING	The printer is parking the fanfold paper
PARK PAPER TEAR IS NECESSARY	The parking action is run with the message for operator to tear the printed paper
PARK PAPER TEAR OFF PAPER	The parking action is already run but the paper remain in the printer path because too long (maximum paper length for automatic parking is 28" (711,2mm). The operator is advise to tear paper.
PATH CHANGING	The path has been changed and the printer is updating the settings
PRESS A KEY NVM CHANGED	The NVM has been changed. Press any key to set the printer. This message appears when the FW is updated.
RELEASE KEYS	This message is displayed when you can release the ON LINE key in the Self-test selection or the PROGRAM key in the Power-on Configuration procedure
REMOTE CONTROL	This message is displayed when the printer operates from remote control (only if the LAN interface is present).
RESET & BREAK	This message is displayed when the input buffer corresponding to the active interface is cleared
SELF TEST	Printing the self-test page.
STARTING UP	The starting-up phase after power on is running
TEAR IF NECESS. EJECT PAPER	These messages are displayed when the printer receives a paper parking command and the TEAR NO item is selected for the tear-off function. Tear off the fanfold then press the PARK key to eject the paper
TEAR IF NECESS. PARK PAPER	These messages are displayed when the printer receives a paper parking command. Tear off the fanfold paper if necessary and then press the PARK key to park the paper
UNLOCKED MENU	When the access to the Printer Setups has been unlocked at the power on, the printer displays this message
WAITING CODE	The special function to download a new FW Release is running
UNLOCKED MENU	When the access to the Printer Setups has been unlocked at the power on, the printer displays this message

For the error messages see "Error Handling" later in this manual

Indicators

 ON-LINE	<ul style="list-style-type: none"> • Lit when the printer can receive and print data (printer online). • Blinks when there is data in the buffer and the printer is offline. • Unlit when the printer is disabled and the buffer does not contain any data, or during the initialization, setup or tests
 PROGRAM	<ul style="list-style-type: none"> • Lit when one of the printer setup procedures has been selected: <i>Program Configuration</i> or <i>Power-On Configuration</i>
 ALTERNATE	<ul style="list-style-type: none"> • Lit when the alternate function of the keys has been enabled pressing the ALTERNATE key
 FRONT 1	<ul style="list-style-type: none"> • Lit when the Front1 paper path is selected • Unlit when the Front1 paper path is not selected
 FRONT 2	<ul style="list-style-type: none"> • Lit when the Front2 paper path is selected • Unlit when the Front2 paper path is not selected

Function Keys

Pressing the function keys it is possible to activate the functions indicated by the word or symbol signed near the key. Each key may have different functions, according to the selected function modes: *Normal*, *Alternate* or *Program*.

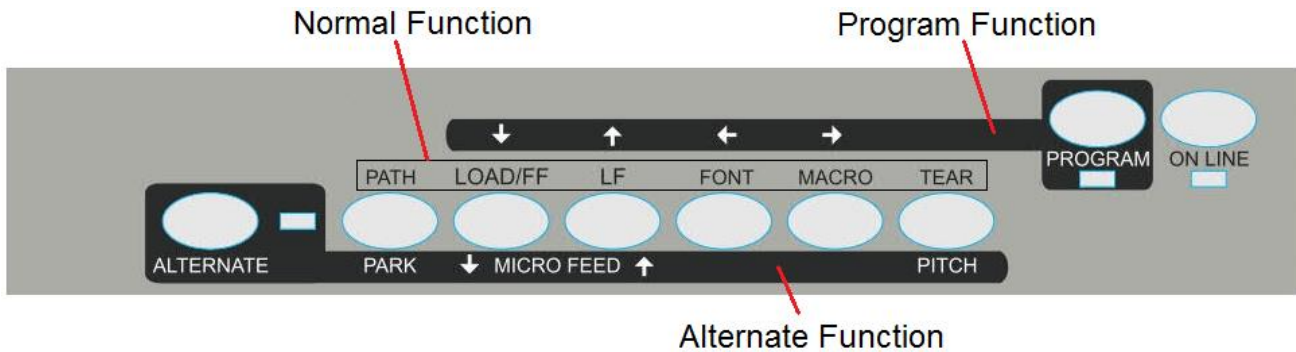

Normal Function	The normal function of the keys is written above the keys and does not require any previous action to select it.
Alternate Function	The alternate function of the keys is written below the keys and is selected pressing the ALTERNATE key. When the alternate function of the keys is selected, the ALTERNATE indicator is lit and the display shows ALTERNATE.
Program Function	The program function of the keys is selected pressing the PROGRAM key, where: <ul style="list-style-type: none"> • If you press the key while powering the printer on, the Power-On Configuration is selected. • If you press the key when the printer is enabled without printing or disabled (ON LINE indicator unlit), the Program Setup is selected. • In the Program Setup mode only the four arrow keys and the PROGRAM key are enabled and the PROGRAM indicator is lit
Special Function	The special function means a specific function of a key or a combination of two or more keys. The detailed function can be found in the Maintenance Manual of the printer.

ON LINE Key

ON LINE	Normal Function	Enables or disables the printer. <ul style="list-style-type: none"> If this key is pressed while powering the printer on, the self test is printed; the printout is stopped pressing this key again. In an error condition, once the error cause has been removed, press this key to enable the printer Pressing this key with MACRO and TEAR, lock or unlock the access to the printer setups. See later "How to Lock/Unlock the Printer Setups" section.
	Program Function	Pressing this key, the input buffer is cleared. The message RESET & BREAK is displayed
	Special Function	Pressing this key together the MACRO key at power on starts the T&D tests (Test & Diagnostic).

PROGRAM Key

PROGRAM	Normal Function	Enables the printer setups as follows: Pressing this key while powering on the printer, the Power-On Configuration is selected. Pressing this key when the printer is enabled without printing or disabled the Program Setup is enabled (PROGRAM indicator lit).
	Program Function	Exits the printer setups

MACRO Key

MACRO	Normal Function	<ul style="list-style-type: none"> Selects one of the user macros (Macro 1, Macro 2, Macro 3 or Macro 4). If you want to select the displayed macro, wait for 2 seconds without pressing any key and the parameters of this macro will be set. Pressing this key with ONLINE and TEAR, lock or unlock the access to the printer setups. See later "How to Lock/Unlock the Printer Setups" section.
→	Program Function	Scrolls the parameters of the functions or macros forwards
	Special Function	Pressing this key together the ON LINE key at power on starts the T&D tests (Test & Diagnostic)

FONT Key

FONT	Normal Function	Selects the font to be used with the currently selected pitch. The selected font is valid until the printer is turned off or a new font is selected using this key.
←	Program Function	Scrolls the parameters of the functions or macros backwards.
	Special Function	Pressing this key together the ALTERNATE key at power on resets the Printer Statistic.

LF Key

LF	Normal Function	Performs a line feed according to the current line spacing settings.
MICROFEED	Alternate Function	Moves the paper forward in microsteps. Keeping the key pressed the paper is moved continuously at increasing speed.
↑	Program Function	Scrolls the setup and macro functions backwards..
	Special Function	Pressing this key together the MACRO key at power on starts the updating of the FW Release

LOAD/FF Key

FF	Normal Function	Executes a Form Feed (FF). When paper is loaded into the printer, it advances to the following page; if no paper advanced, it is positioned for printing
MICROFEED	Alternate Function	Moves the paper backward in microsteps. Keeping the key pressed the paper is moved continuously at increasing speed.
↑	Program Function	Scrolls the setup and macro functions forwards..

ALTERNATE Key

ALTERNATE	Normal Function	<p>Enables the alternative key functions.</p> <p>If the printer is receiving print data, press the ON LINE key before pressing the ALTERNATE key.</p> <p>If no print data is in the print buffer, press the ALTERNATE key, the printer will go offline.</p> <p>The display then shows ALTERNATE to indicate that the Alternate Function of the keys is enabled (ALTERNATE indicator lit).</p> <p>May be used to abort paper parking procedure. See also "How to Handle the Paper Parking", later in this manual.</p> <p>When the printer is in Program Setup Mode, this key is disabled.</p>
	Alternate Function	Disables the alternative key functions
	Special Function	Pressing this key together the FONT key at power on resets the Printer Statistic.

TEAR/PITCH Key

TEAR		Normal Function	<ul style="list-style-type: none"> Moves the paper to the tear-off position (TEAR NORMAL function must be selected in the Program Setup). Pressing this key with ONLINE and MACRO, lock or unlock the access to the printer setups. See later "How to Lock/Unlock the Printer Setups" section.
PITCH		Alternate Function	Selects the pitch to be used with the currently selected font. The selected pitch is valid until the printer is turned off.

PATH/PARK Key

PATH		Normal Function	Selects one of the paper paths in offline status. The parameters of the displayed path are set after 2 seconds without pressing any key.
PARK		Alternate Function	Parks the paper in the currently selected paper path.

Printer Setups

The main printer setup parameters can be selected via the operator panel. The setup parameters are divided into two printer setups, the **Power-On Configuration**, that allows a complete configuration at installation time according to the hardware and the emulation types, and the **Program Setup**, that allows you to set the functions that are the most useful in your daily job. These settings can be selected when the printer is online without printing or offline (ON LINE indicator unlit) and stored in the NVM.

Entering the Printer Setups

- Press the PROGRAM key and keep it pressed at the printer power on until the RELEASE KEYS message is displayed to select the **Power-On Configuration**.
- Press the PROGRAM key when the printer is online without printing or offline (ON LINE indicator unlit) to select the **Program Setup**.

Moving within the Printer Setups

The arrow keys ↑, ↓, ←, → are used to move within the different functions inside the Printer Setups. See the following description of the setup items.

Leaving the Printer Setups

- Pressing the PROGRAM key in the **Power-On Configuration** the printer exits from the setup and the new settings will be automatically saved.
- Pressing the PROGRAM key in the **Program Setup**, the following choice is offered for the storage of the values set:

STORE?	QUIT	The new settings are not activated and the old settings remain valid.
STORE?	SAVE	The new settings are stored permanently in the NVM (Non Volatile Memory).
STORE?	CURRENT	The new settings remain valid until the printer is turned off.

Press the → or ← keys to scan these selections forward and backwards. When the desired setting is displayed, press the PROGRAM key to exit from the Setup.

Printer Setup Item

When the **Program Setup** is run, these are the available ITEM .:

then	<input data-bbox="472 1599 834 1641" type="text" value="PRINT OUT?"/>	Print Program Setup
then	<input data-bbox="472 1680 834 1722" type="text" value="PRINT STATS? NO"/>	Print Statistics
then	<input data-bbox="472 1760 834 1803" type="text" value="USER MACRO"/>	Enter in the Macro Setup
then	<input data-bbox="472 1841 834 1883" type="text" value="CONFIG MENU NO"/>	Enter in the Power-on Configuration
then	<input data-bbox="472 1921 834 1964" type="text" value="HEX DUMP NO"/>	Enter in Hex Dump mode
then	<input data-bbox="472 2002 834 2045" type="text" value="STORE? QUIT"/>	Leaving Setup

Power-On Configuration Setup

The default values of the various functions are indicated in bold.

Entering the Power-On Configuration Setup

1. Make sure that the printer is turned off.
2. Press and hold the PROGRAM key pressed while powering on the printer until the RELEASE KEYS message is displayed. As soon as the PROGRAM key gets released, the following message will be displayed:

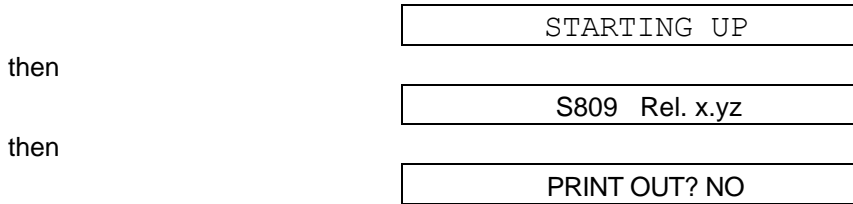

Main Structure

This figure shows the structure of the Power-On Configuration and how to move inside the Setup.

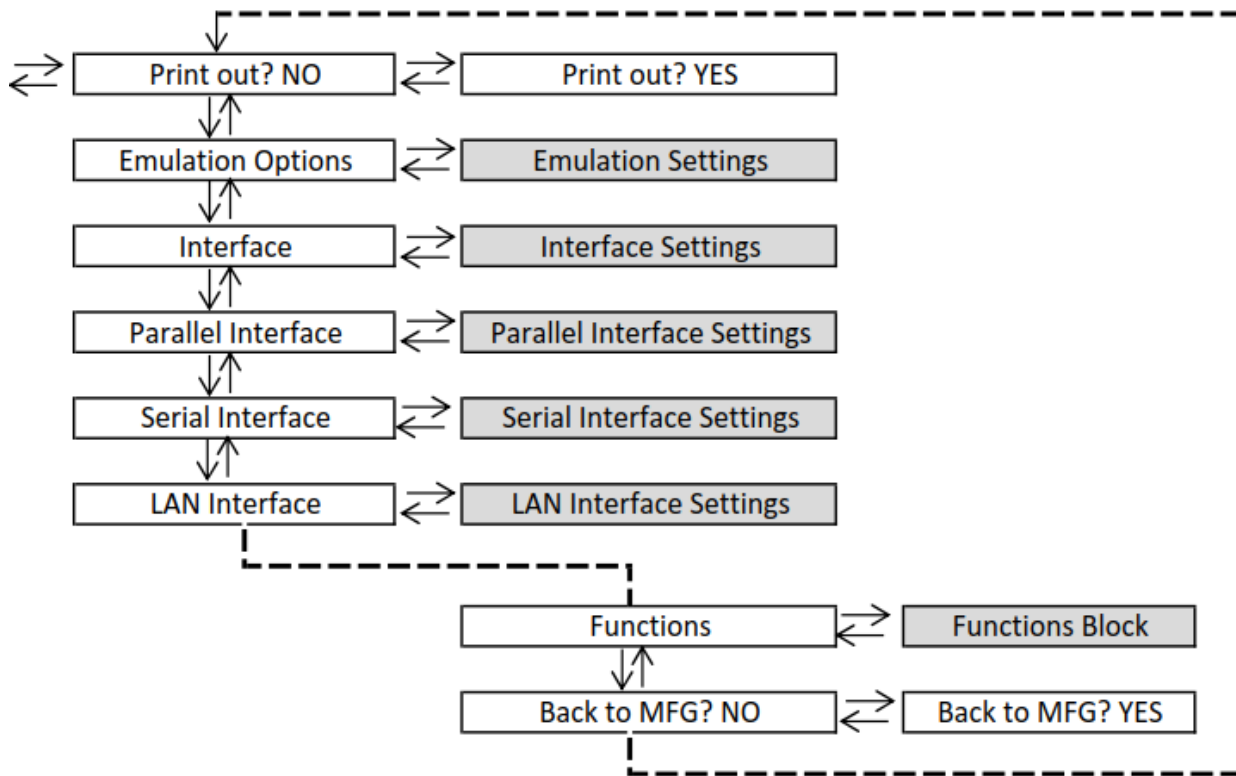

Printout of the Configuration Printer Settings

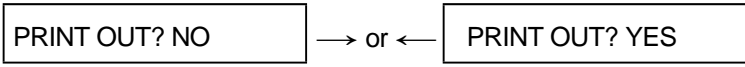

EMUL. OPTIONS

PRINT OUT? NO
PRINT OUT? YES

The Setup is not printed.

The printer setup is printed showing the currently selected values.

The printout starts as soon as you select this value.

-CONFIGURATION SETUP PRINTOUT:		
PRINTER MODEL:	S809	
FIRMWARE CODE:	ver. 1.00 FMW00475	
SERIAL NUMBER:	00000000	
MAC ADDRESS:	00066D211167	
EMUL. OPIONS	EMUL.	EPSON
	CHAR. SET	CS2
	NATION	CP437
	AUTO CR	YES
	AUTO LF	NO
	BAR CODE	NAT.
INTERFACE	I/F TYPE	AUTO
PARALL INTERFACE	1284 BIDIR.	AUTO
	SELECT-IN	HOST
	DATA BITS	8
	INP. BUFFER	2K
SERIAL INTERFACE	SERIAL I/F	232
	BAUD	9600
	DATA BITS	8
	PARITY	NONE
	HANDSHAKE	DTR
	CONNECTION	LOCAL
	INP. BUFFER	2K
LAN INTERFACE	IP ASSIGN	DHCP
	INIT IP ADDRESS	000.000.000.000
	INIT NET MASK	000.000.000.000
	DEF. GATEWAY ID	000.000.000.000
	INIT HOST NAME	PTX_211167
	INIT WORKGROUP	workgroup
	SMTP ENABL.	YES
	MAIL SERV. ADDRES	000.000.000.000
	EMAIL ADDRESS	
	SENDER ADDRESS	
	LPR ENABL.	YES
	FTP ENABL.	YES
	TELNET ENABL.	YES
	DIRIP ENABL.	YES
	HTTP ENABL.	YES
	SNNMPD ENABL.	YES
	SMBD ENABL.	YES
FUNCTIONS	BUZZER	YES
	BAR CODE	120DPI
	TEXT DIRECT	BI
	GRAPH DIRECT	BI
	BARCODES DIR.	UNI
	GRAPH H.S.	YES
	P.ON PATH	MACRO
	MENU	ENGLISH
	F1 JAM SENS.	YES
	TEAR ADJUST	0

Emulation Options

This setup defines the available options according to the selected emulation and is structured as follows:

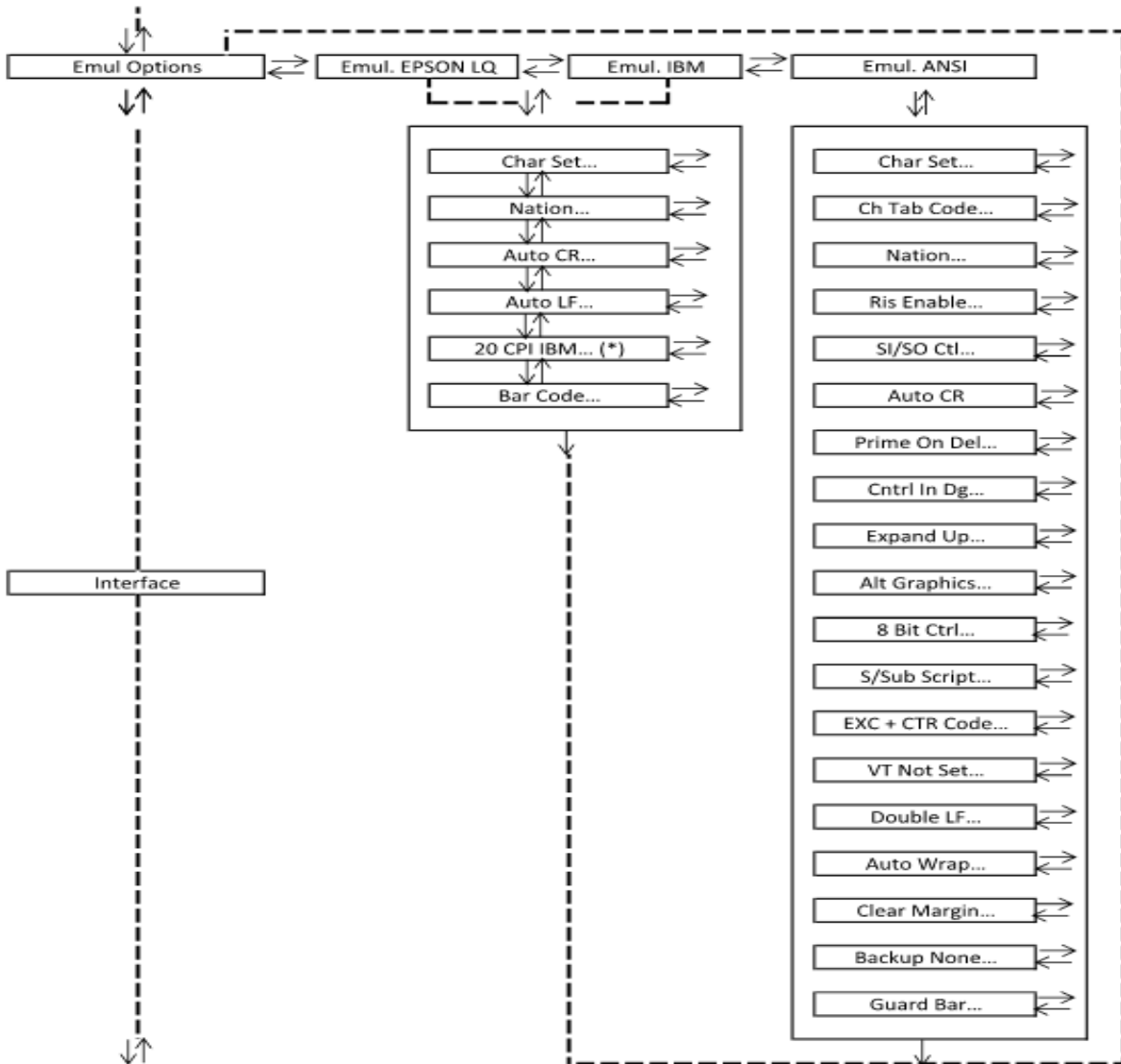

Setting the Emulation Options

Printer Emulation

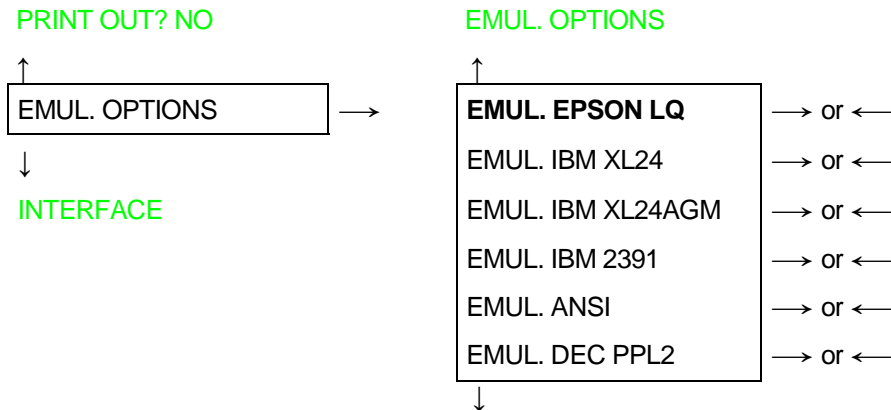

CHAR. SET CS2

- EMUL EPSON LQ The printer uses the EPSON LQ Series emulation.
- EMUL EPSON 1600K (*) The printer uses the EPSON LQ1600K emulation.
Note: The EPS 1600K is only available on the S809 printer with the DBCS controller is installed. It is the default emulation.
- EMUL IBM XL24 The printer uses the IBM Proprinter XL24 emulation.
- EMUL IBM XL24AGM The printer uses the IBM Proprinter XL24 AGM emulation.
- EMUL. IBM 2391 The printer uses the IBM Personal 2391+ emulation.
- EMUL. ANSI The printer uses the ANSI 3.64 emulation.
- EMUL. DEC PPL2 The printer uses the DEC PPL2 emulation.

If ANSI or DEC emulations have been selected, specific ANSI or DEC parameters are available, see later on in this manual.

EPSON Character Sets

EMUL. EPSON LQ



NATION CP437

These items select the character set to be used in EPSON emulation.

IBM Character sets

EMUL. IBM xxx

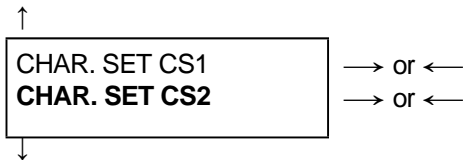

NATION CP437

These items select the character set to be used in IBM Proprinter emulation.

EPSON National Character sets

CHAR. SET CS2

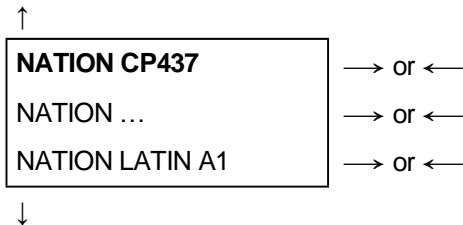

AUTO CR YES

The following national character sets are available:

CP 437	CP437 G	96GREEK	CP850	CP851	CP 852	CP 853	CP 855
CP 857	CP 858	CP 860	CP 862	CP 863	CP 864	CP 865	CP 866
CP 867	CP 876	CP 877	CP 1250	CP 1251	CP 1252	CP 1253	CP 1254
CP 1255	CP 1256	CP 1257	GOST	TASS	MAZOWIA	ISO 8859/1	ISO 8859/2
8859/3	ISO 8859/4	ISO 8859/5	ISO 8859/6	ISO 8859/7	ISO 8859/8	ISO 8859/9	ISO 8859/15
CP 437SL	CP 1098	UKRAIN	KOI8-U	FARSI1	FARSI2	USA	FRANCE
GERMANY	ENGLAND	DENMARK1	SWEDEN	ITALY	SPAIN1	JAPAN	NORWAY
DENMARK2	SPAIN2	LATIN A1					

The CP 858 and ISO 8859/15 character sets contain the Euro character

IBM National Character Sets

CHAR. SET CS2

↑

NATION CP437	→ or ←
NATION ...	→ or ←
NATION FARSI2	→ or ←

↓

AUTO CR NO

The following national character sets can be selected:

CP 437	CP437 G	96GREEK	CP850	CP851	CP 852	CP 853	CP 855
CP 857	CP 858	CP 860	CP 862	CP 863	CP 864	CP 865	CP 866
CP 867	CP 876	CP 877	CP 1250	CP 1251	CP 1252	CP 1253	CP 1254
CP 1255	CP 1256	CP 1257	GOST	TASS	MAZOWIA	ISO 8859/1	ISO 8859/2
ISO 8859/3	ISO 8859/4	ISO 8859/5	ISO 8859/6	ISO 8859/7	ISO 8859/8	ISO 8859/9	ISO 8859/15
CP 437SL	CP 1098	UKRAIN	KOI8-U	FARSI1	FARSI2		

The CP 858 and ISO 8859/15 character sets contain the Euro character

CR Code Behavior

NATION xxx

↑

AUTO CR NO	→ or ←
AUTO CR YES	→ or ←

↓

AUTO LF NO

- AUTO CR NO No automatic carriage return is performed after a LF, VT or ESCJ code. Default value in IBM emulation.
- AUTO CR YES The printer performs an automatic carriage return after a LF, VT or ESCJ code. Default value in EPSON emulation.

LF Code Behavior

AUTO CR xx

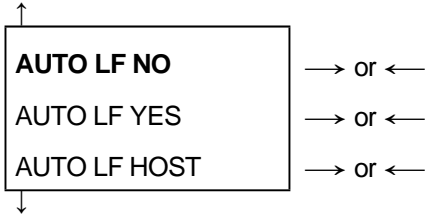

20 CPI IBM NO

or

BAR CODE NATIV

- AUTO LF NO No Automatic LF after CR.
- AUTO LF YES Automatic LF after CR.
- AUTO LF HOST Only in EPSON emulation. The printer checks the AUTOFEEDXT signal coming from the host and executes an automatic LF after CR, if the signal is low.

IBM Compressed Printing

These items are displayed only if the IBM emulation is selected.

AUTO LF NO

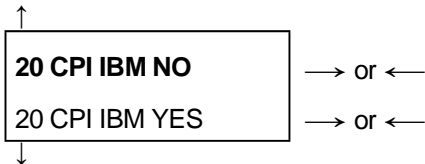

BAR CODE NATIV

- 20 CPI IBM NO The compressed printing is performed at 17.1 cpi.
- 20 CPI IBM YES The compressed printing is performed at 20 cpi.

Bar code mode

20 CPI IBM NO

or

AUTOLF NO

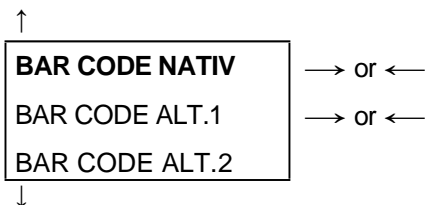

EMUL. OPTIONS

- BAR CODE NATIV Enables bar code printing using the native commands (DC4, DC4, ...).
- BAR CODE ALT.1 Enables bar code printing using ANSI commands even if the emulation in use is EPSON or IBM.
- BAR CODE ALT.2 Enables bar code printing using xxxx commands even if the emulation in use is EPSON or IBM.

Interface

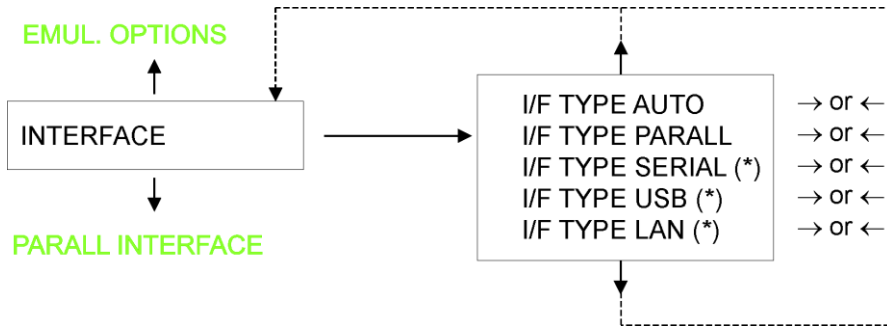

Interface Type Settings

Depending upon the installed Controller Board, the printer model can be equipped with different interfaces to connect to the host system.

The possible interfaces are:

	S809 SBCS	S809 DBCS
• Parallel Centronics	YES	YES
• Serial 232C	YES	YES
• USB	YES	YES
• Ethernet LAN 10/100	YES	YES

The following paragraphs describe how to configure the parameters of the interfaces.

- AUTO All the interfaces installed onto the interface board (controller) are active and the hot port feature is operative.
- PARALLEL Only the Centronics Parallel Interface is active. Hot Port is not operative.
- SERIAL Only the Serial RS232 Interface is active. Hot Port is not operative.
- USB Only the USB Interface is active. Hot Port is not operative.
- LAN-A Only the Ethernet LAN ASCII Interface is active. Hot Port is not operative.

Parallel Interface

This setup defines the use of the parallel interface and is structured according to the interface specific parameters.

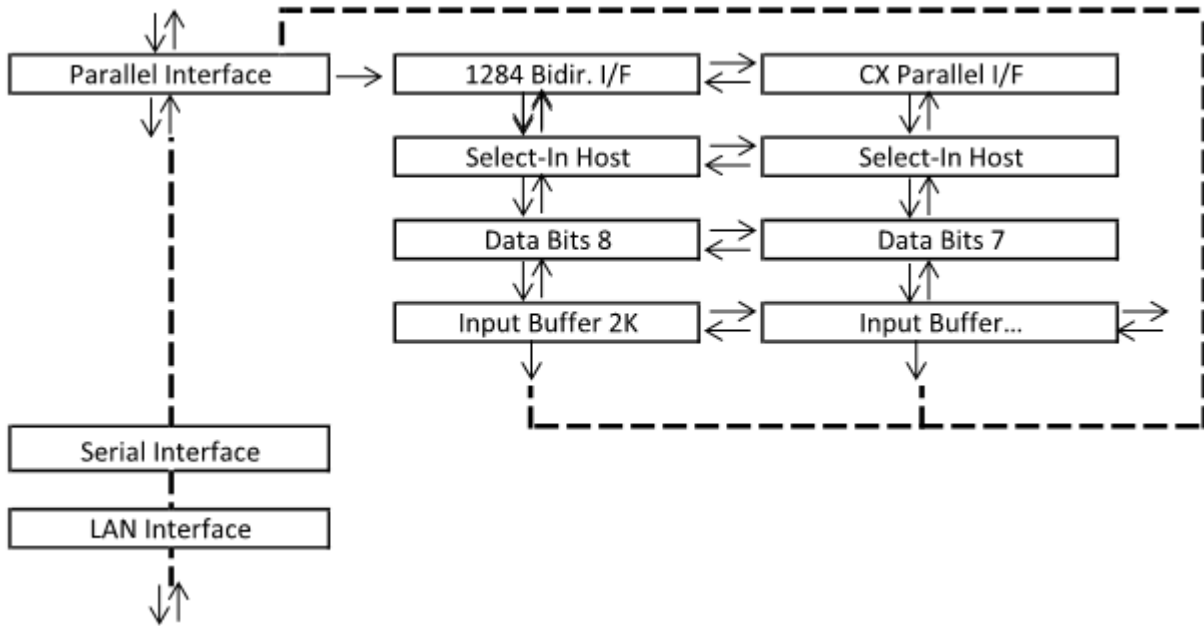

Setting the Parallel Interface Parameters

Interface Type

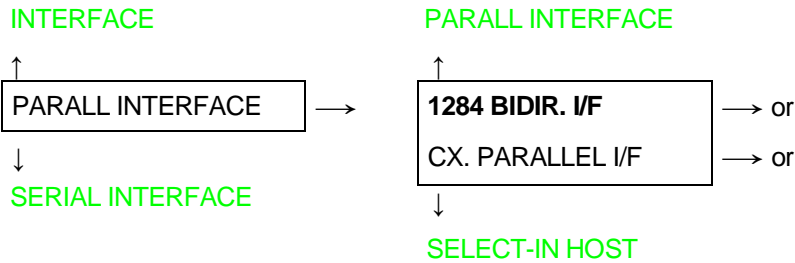

1284 BIDIR. I/F Bidirectional IEEE 1284 parallel interface.
 CX. PARALLEL I/F Centronics type parallel interface (mono-directional).

Setting the Select-In Signal

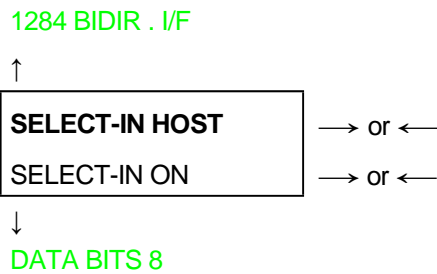

SELECT-IN HOST The printer checks the SELECT-IN signal coming from the host.
 SELECT-IN ON The SELECT-IN signal of the parallel interface is ignored and treated always as ON.

Number of Data Bits

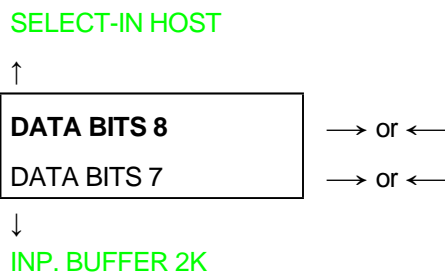

Selection of the number of data bits: 7 or 8.

Input Buffer Size

DATA BITS 8

↑

INP. BUFFER 256

→ or ←

INP. BUFFER 2K

→ or ← INP.

BUFFER 12K

→ or ← INP.

BUFFER 32K

→ or ← INP.

BUFFER 64K

→ or ← INP.

BUFFER 128K

→ or ←

↓

PARALL. INTERFACE

Selects the input buffer size.

Serial Interface

The following Serial Interface Parameters will display only if the Serial Interface is present

This setup defines the use of the serial interface and is structured according to the interface specific parameters.

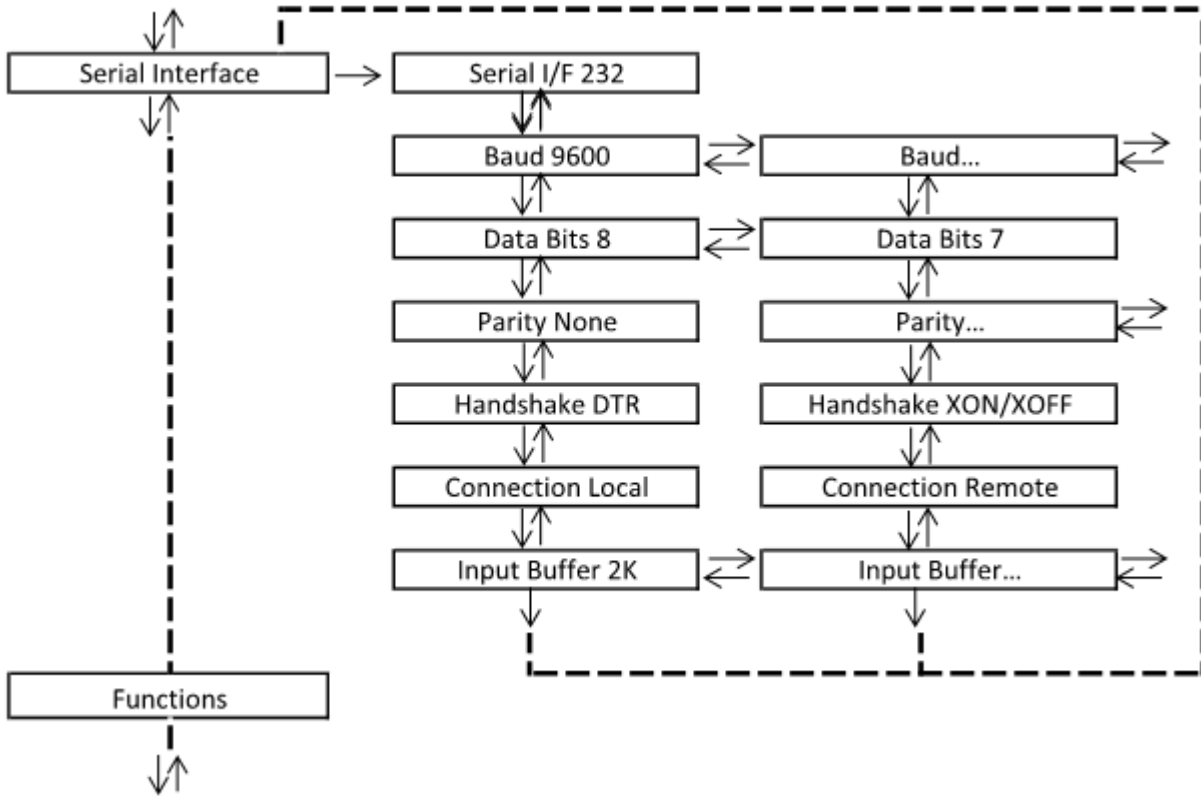

Setting the Serial Interface Parameters

Interface Type

PARALL INTERFACE

SERIAL INTERFACE

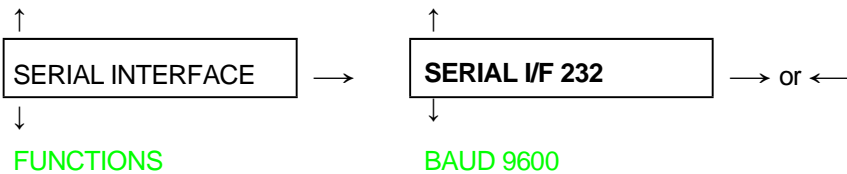

SERIAL I/F 232

It is available the serial interface RS-232/C only.

Baud Rate

SERIAL I/F 232

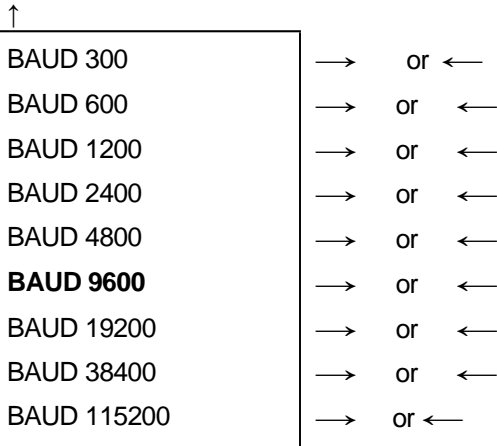

↓
DATA BITS 8

The baud rate is selected in bits per second. The above values can be selected.

Number of Data Bits

BAUD 9600

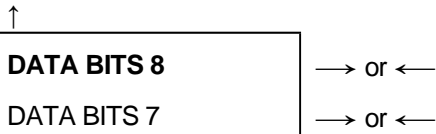

↓
PARITY NONE

Selection of the number of data bits: 7 or 8.

Parity Check

DATA BITS 8

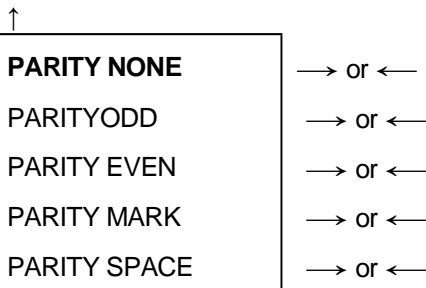

↓
HANDSHAKE DTR

- PARITY NONE Data does not have a parity bit, i.e. 8 bit data are transferred and the parity check is disabled.
- PARITY ODD Parity check is enabled for odd parity.
- PARITY EVEN Parity check is enabled for even parity.
- PARITY MARK Parity check is disabled and the transmitted parity bit is always a Mark.
- PARITY SPACE Parity check is disabled and the transmitted parity bit is always a Space.

Handshake Protocol

PARITY NONE



CONNECTION LOCAL

HANDSHAKE DTR The Handshake is performed using the DTR Protocol. HANDSHAKE XONXOF
 HANDSHAKE XONXOFF The Handshake is performed using the XON-XOFF Protocol.

Connection Type

HANDSHAKE DTR

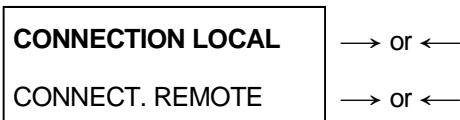

INP. BUFFER 2K

Selects the connection type: local or remote.

Input Buffer Size

CONNECTION LOCAL

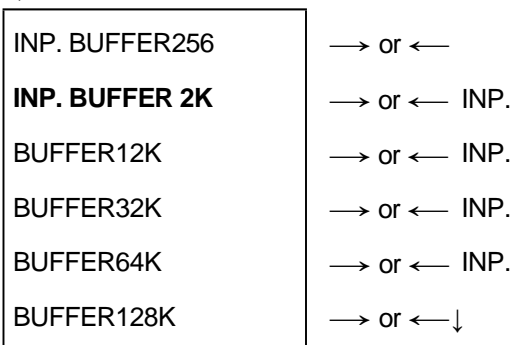

SERIAL INTERFACE

Selects the input buffer size.

LAN Interface

The following LAN interface parameters will display only if the Ethernet 10/100 Mbit interface is present

This setup defines the use of the LAN interface and is structured according to the interface specific parameters.

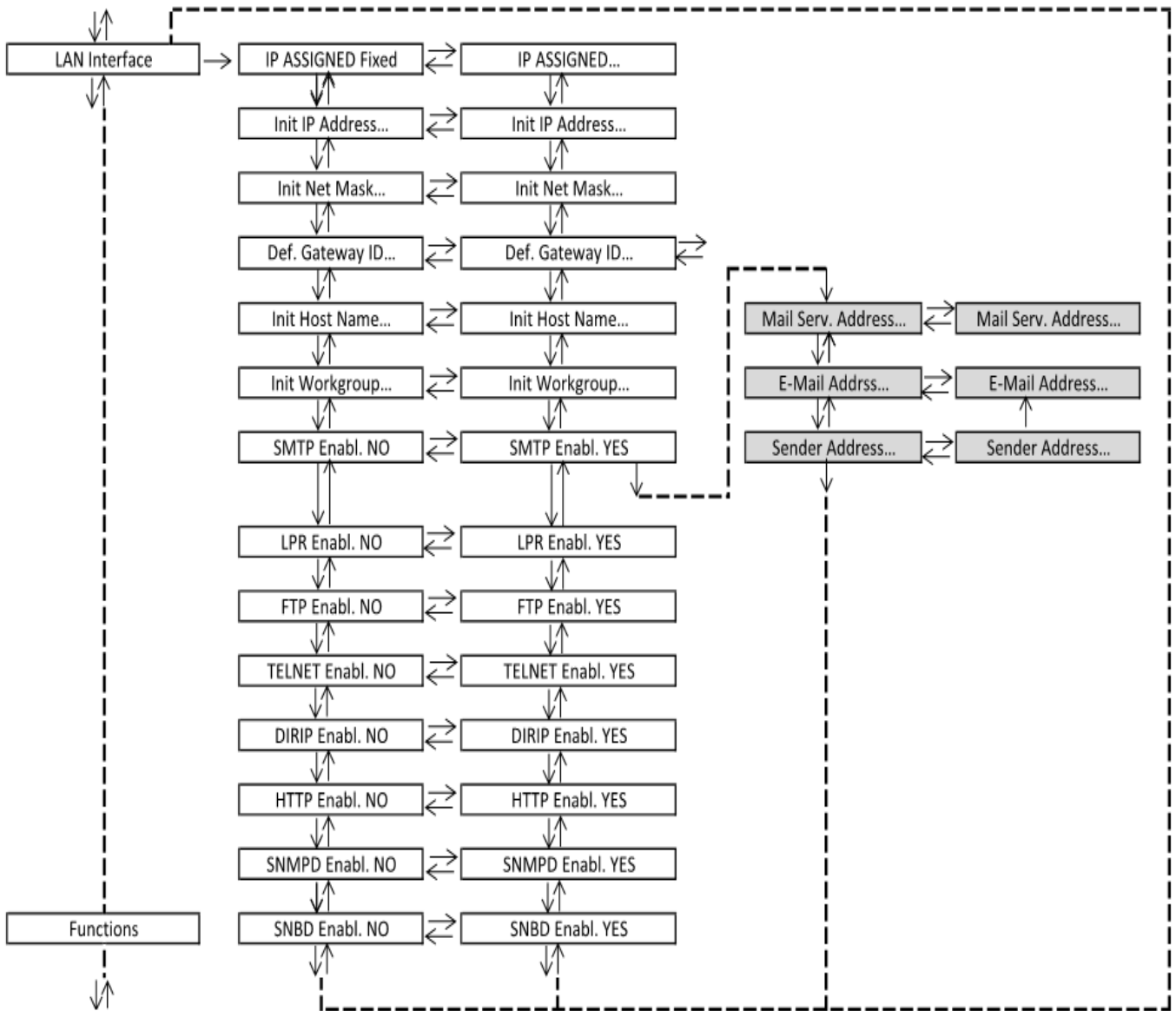

Setting the LAN Interface Parameters

IP Assignment

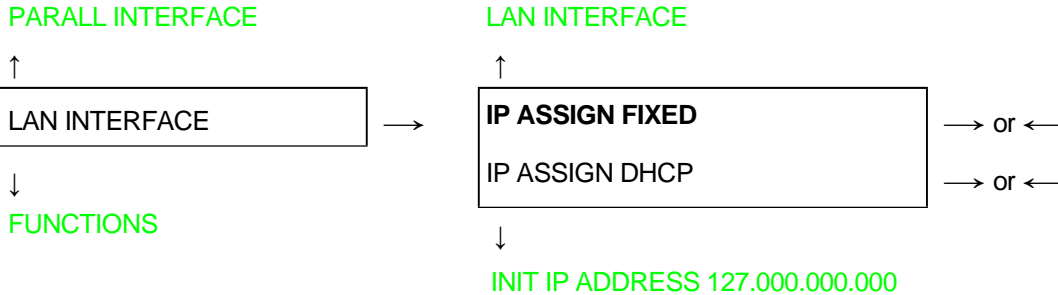

- IP ASSIGN FIXED Assigns the static or fixed IP address.
- IP ASSIGN DHCP Assigns the dynamic IP address (DHCP protocol).

Init IP Address

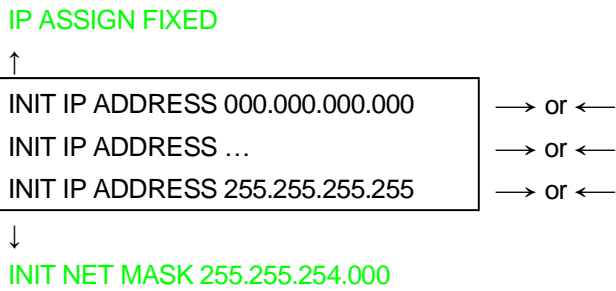

These values set the INIT IP address. The IP address is represented by a decimal notation where the decimal values are divided by points in four fields. Each field ranges between 0 and 255. Use the ← or → keys to increase or decrease the values in one field and the ↓ or ↑ keys to move to the next field (↓ to move to the right and ↑ to move to the left). The default value is 127.000.000.000.

Init Net Mask

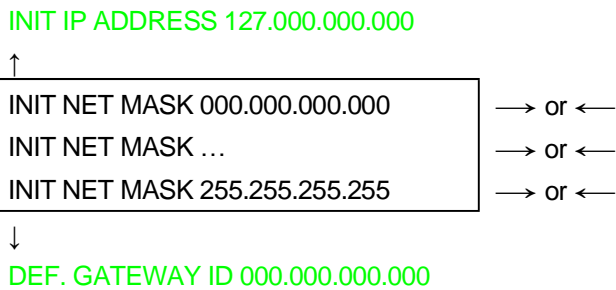

These values set the INIT net mask number. This number is represented by a decimal notation where the decimal values are divided by points in four fields. Each field ranges between 0 and 255. Use the ← or → keys to increase or decrease the values in one field and the ↓ or ↑ keys to move to the next field (↓ to move to the right and ↑ to move to the left). The default value is 255.255.254.000.

ID Default Gateway

INIT NET MASK 255.255.254.000

↑

DEF. GATEWAY ID 000.000.000.000	→ or ←
DEF. GATEWAY ID ...	→ or ←
DEF. GATEWAY ID 255.255.255.255	→ or ←

↓

INIT HOST NAME CMP_XXXXXX

These values set the ID default gateway number. This number is represented by a decimal notation where the decimal values are divided by points in four fields. Each field ranges between 0 and 255. Use the ← or → keys to increase or decrease the values in one field and the ↓ or ↑ keys to move to the next field (↓ to move to the right and ↑ to move to the left).

Init Host Name

DEF. GATEWAY ID 000.000.000.000

↑

INIT HOST NAME	→ or ←
----------------------	--------

PROGRAM key

↓

INIT WORKGROUP CMP_GROUP

The host is identified by a name. This function allows to create the name of the init host using a 14-character string. Use the ← or → keys to increase or decrease the values in one field and the ↓ or ↑ keys to move to the next field (↓ to move to the right and ↑ to move to the left). Press the PROGRAM key to save the selected init host name. The default name is CMP_XXXXXX.

Init Workgroup Name

INIT HOST NAME CMP_XXXXXX

↑

INIT WORKGROUP	→ or ←
----------------------	--------

PROGRAM key

↓

SMTP ENABL. NO

The workgroup is identified by a name. This function allows to create the name of the workgroup using a 14-character string. Use the ← or → keys to increase or decrease the values in one field and the ↓ or ↑ keys to move to the next field (↓ to move to the right and ↑ to move to the left). Press the PROGRAM key to save the selected init workgroup name. The default name is workgroup.

Enable/Disable the SMTP Service

INIT WORKGROUP workgroup

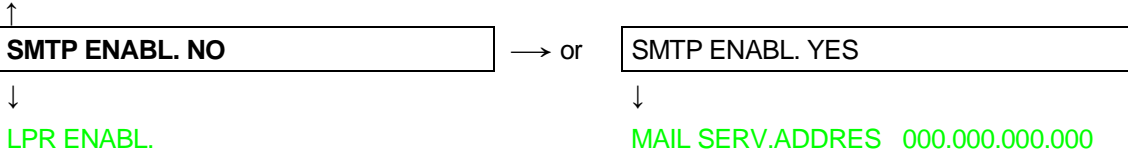

SMTP ENABL. NO Disables the SMTP (Simple Mail Transfer Protocol) service, that is disables the reception/transfer/error service of the e-mail.

SMTP ENABL. YES Enables the SMTP (Simple Mail Transfer Protocol) service, that is enables the reception/transfer/error service of the e-mail.

Mail Server Address

This item is displayed only if the SMTP ENABL. function is selected in YES

SMTP ENABL. YES

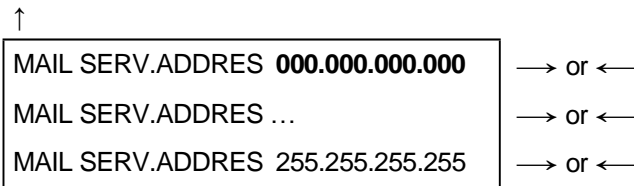

EMAIL ADDRESS xxxxxxxxxxxx

These values set the mail server address. This number is represented by a decimal notation where the decimal values are divided by points in four fields. Each field ranges between 0 and 255. Use the ← or → keys to increase or decrease the values in one field and the ↓ or ↑ keys to move to the next field (↓ to move to the right and ↑ to move to the left).

E-mail Address

This item is displayed only if the SMTP ENABL. function is selected YES

MAIL SERV.ADDRES

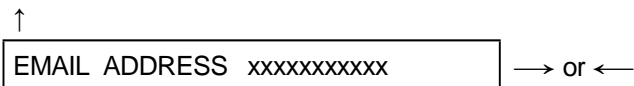

SENDER ADDRESS xxxxxxxxxxxx

This function allows to write the e-mail address where you can notify the failures. Use the ← or → keys to increase or decrease the values in one field and the ↓ or ↑ keys to move to the next field (↓ to move to the right and ↑ to move to the left). Press the PROGRAM key to save the e-mail address.

Sender Address

This item is displayed only if the SMTP ENABL. function is selected YES

EMAIL ADDRESS xxxxxxxxxxxx

↑

SENDER ADDRESS xxxxxxxxxxxx → or ←

↓

LPR ENABL.

This function identifies the address of the sender's e-mail using a string of characters. Use the ← or → keys to increase or decrease the values in one field and the ↓ or ↑ keys to move to the next field (↓ to move to the right and ↑ to move to the left). Press the PROGRAM key to save the sender's e-mail address.

Enable/Disable the LPR Service

SENDER ADDRESS xxxxxxxxxxxx or SMTP ENABL. NO

↑

LPR ENABL. YES → or LPR ENABL. NO

↓

FTP ENABL.

LPR ENABL. YES Enables the LPR (Line Printer Remote Protocol) service.
LPR ENABL. NO Disables the LPR (Line Printer Remote Protocol) service

Enable/Disable the FTP Service

LPR ENABL

↑

FTP ENABL. YES → or FTP ENABL. NO

↓

TELNET ENABL..

FTP ENABL. YES Enables the FTP (File Transfer Protocol) service.
FTP ENABL. NO Disables the FTP (File Transfer Protocol) service

Enable/Disable the TELNET Service

FTP ENABL

↑

TELNET ENABL. YES → or TELNET ENABL. NO

↓

DIRIP ENABL..

TELNET ENABL. YES Enables the TELNET service.

TELNET ENABL. NO Disables the TELNET service

Enable/Disable the DIRIP Service

TELNET ENABL

↑
 DIRIP ENABL. YES → or DIRIP ENABL. NO

↓

HTTP ENABL..

DIRIP ENABL. YES Enables the DIRIP service.
 DIRIP ENABL. NO Disables the DIRIP service

Enable/Disable the HTTP Service

DIRIP ENABL

↑
 HTTP ENABL. YES → or HTTP ENABL. NO

↓

TELNET ENABL..

HTTP ENABL. YES Enables the HTTP (HyperText Transfer Protocol) service.
 HTTP ENABL. NO Disables the HTTP (HyperText Transfer Protocol) service

Enable/Disable the SNMPD Service

HTTP ENABL

↑
 SNMPD ENABL. YES → or SNMPD ENABL. NO

↓

SMBD ENABL..

SNMPD ENABL. YES Enables the SNMPD service.
 SNMPD ENABL. NO Disables the SNMPD service

Enable/Disable the SMBD Service

SNMPD ENABL

↑
 SMBD ENABL. YES → or SMBD ENABL. NO

↓

FUNCTION..

SMBD ENABL. YES Enables the SMBD service.
 SMBD ENABL. NO Disables the SMBD service

Functions

The Functions item groups the following printer functions:

- Buzzer setting,
- Paper loading sequence,
- Bar code density,
- Text printing direction,
- Graphics printing direction,
- Bar code printing direction,
- Graphics printing speed,
- Paper path at power on,
- Language of the display messages,
- Paper tractor jam sensors (if the 6 pin Front1/Front2 Push tractors are installed),
- Tear-off position adjustment.

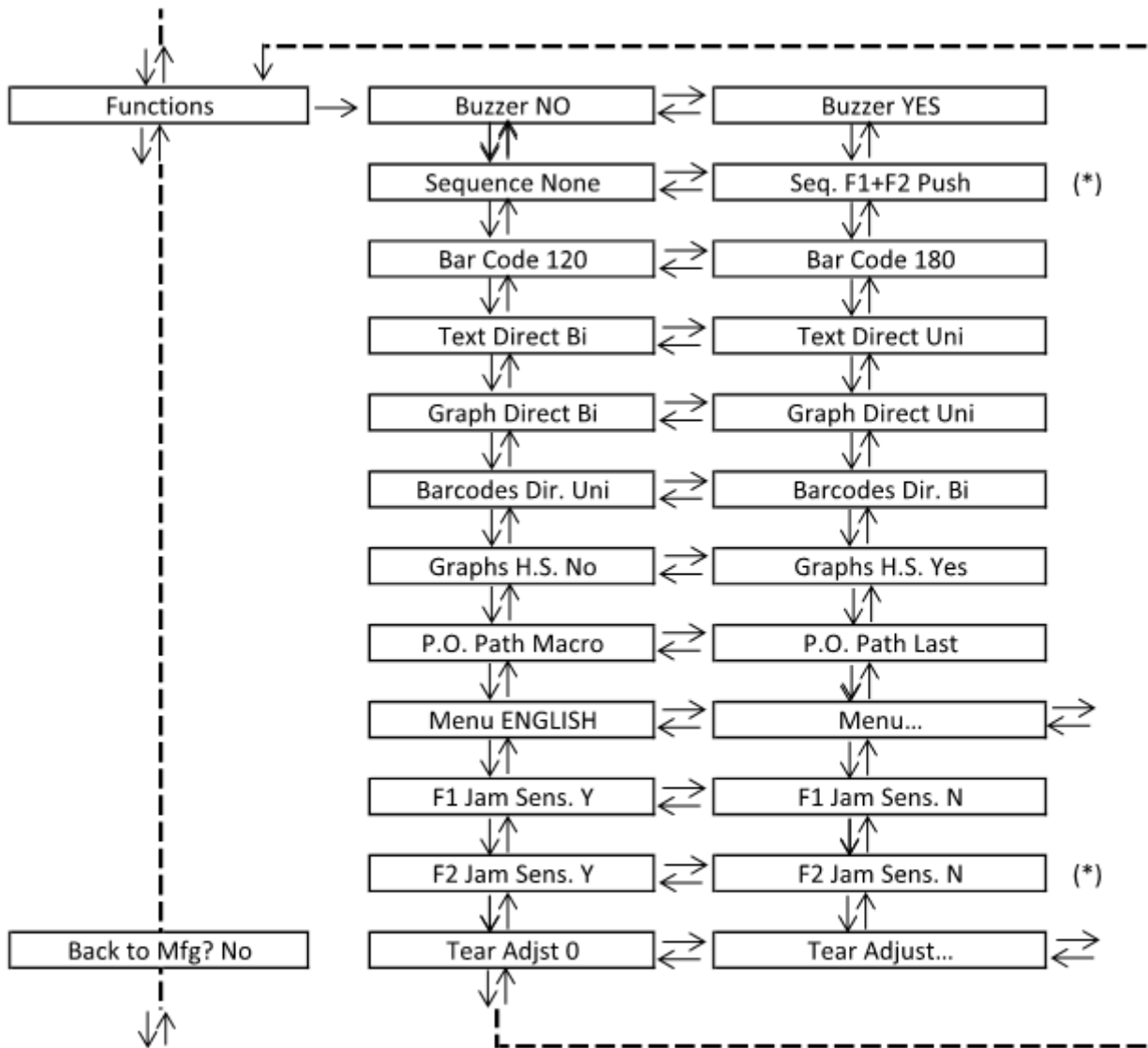

(*) This item is displayed only if the 6 pin Front2 push tractor option is installed.

Setting the Functions Group Items

Enable/Disable the Buzzer

SERIAL INTERFACE (*)

or

LAN INTERFACE (**)

FUNCTIONS

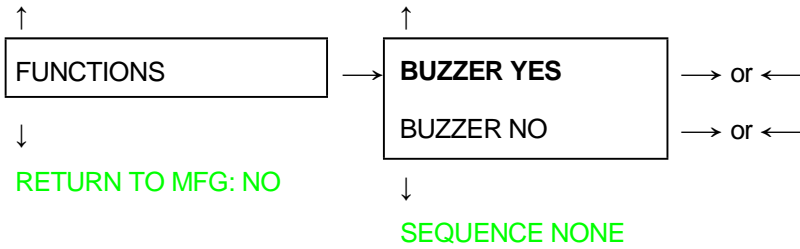

Enable or disables the buzzer.

(*) If Serial Interface is present.

(**) If LAN Interface is present.

Paper Loading Sequence

BUZZER YES

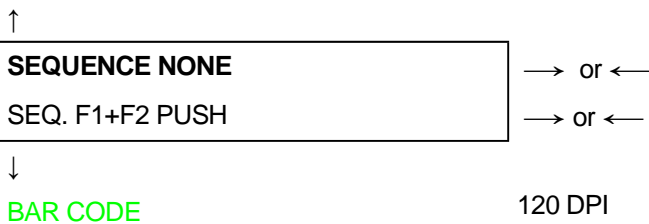

These items are displayed only if the accessories to which they refer are installed

SEQUENCE NONE
SEQ. F1+F2 PUSH

The paper is fed only through the path selected by operator panel.

The paper is fed firstly with the Front1 push tractor and successively through the Front2 push tractor option.

Bar Code Density

SEQUENCE NONE

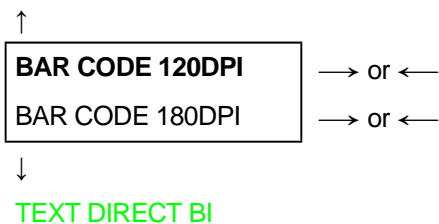

Selects the bar code print density: 120 or 180 dpi.

Text Print Direction

BAR CODE 120DPI



TEXT DIRECT BI	→ or ←
TEXT DIRECT UNI	→ or ←



GRAPH DIRECT BI

Selects the print direction for text: bidirectional or unidirectional.

Graphics Print Direction

TEXT DIRECT BI



GRAPH DIRECT BI	→ or ←
GRAPH DIRECT UNI	→ or ←



BARCODES DIR. UNI

Selects the print direction for graphics: bidirectional or unidirectional.

Bar Codes Print Direction

GRAPH DIRECT BI



BARCODES DIR. BI	→ or ←
BARCODES DIR. UNI	→ or ←



GRAPH H.S. YES

Selects the print direction for bar codes: bidirectional or unidirectional.

Graphics Printing Speed Selection

BARCODES DIR. UNI



GRAPH H.S. NO	→ or ←
GRAPH H.S. YES	→ or ←



P. ON PATH MACRO

GRAPH H.S. NO

Selects graphics printing (bit image data) at normal speed.

GRAPH H.S. YES

Selects graphics printing (bit image data) at high speed.

Paper Path at Power-On

GRAPH H.S. YES

↑

P. ON PATH MACRO	→ or ←
P. ON PATH LAST	→ or ←

↓

MENU ENGLISH

P. ON PATH MACRO The paper path at power-on is the one from the default Macro.

P. ON PATH LAST The paper path at power-on is the last one that was selected before the printer was powered off.

Selection of the Language of the Display Messages

P. ON PATH MACRO

↑

MENU ENGLISH	→ or ←
MENU ITALIANO	→ or ←
MENU FRANCAIS	→ or ←
MENU ESPANOL	→ or ←
MENUE DEUTSCH	→ or ←

↓

F1 JAM SENS. Y (if 6 pin Front1 Push Tractor option is installed)

or

TEAR ADJUST:xxx

These items are self-explaining.

See also “Selecting the Display Language” before in this manual

Enable/Disable Front1 Tractor Jam Sensor

This item is displayed only if the 6 pin Front1 Push Tractor option is installed

MENU ENGLISH

↑

F1 JAM SENS. Y	→ or ←
F1 JAM SENS. N	→ or ←

↓
 F2 JAM SENS. Y (if 6 pin Front2 Push Tractor option is installed)

or

TEAR ADJUST:xxx

F1 JAM SENS. Y Enables the paper jam sensor located in the 6 pin Front1 push tractor option.
 F1 JAM SENS. N Disables the paper jam sensor located in the 6 pin Front1 push tractor option.

Enable/Disable Front2 Tractor Jam Sensor

This item is displayed only if the 6 pin Front2 push tractor option is installed

F1 JAM SENS. Y

↑

F2 JAM SENS. Y	→ or ←
F2 JAM SENS. N	→ or ←

↓
 TEAR ADJUST: xxx

F2 JAM SENS. Y Enables the paper jam sensor located in the 6 pin Front2 push tractor option.
 F2 JAM SENS. N Disables the paper jam sensor located in the 6 pin Front2 push tractor option.

Adjusting the Tear-Off Position

F2 JAM SENS. Y (if 6 pin Front2 Push Tractor is installed)

or

F1 JAM SENS. Y (if 6 pin Front1 Push Tractor is installed)

or

MENU ENGLISH

↑

TEAR ADJUST: +30	→ or ←
TEAR ADJUST: ...	→ or ←
TEAR ADJUST: -390	→ or ←

↓
 FUNCTIONS

TEAR ADJUST: xxx These values adjust the distance between the Tear-Off Perforation and the Tear-Off Bar. The values correspond to 1/180 inch units, i.e. the tuning ranges between +1/6 and -13/6 inch. **0** is the default value.

See also “How to Use the Tear-Off Function”, later in this Chapter

Resetting to Factory Default Values

With the BACK TO MFG function it is possible to reset all items in the *Power On Configuration Setup* and in the *Program Setup* to their factory default values. This may be useful if you do not remember the values you set in the setups, or because you simply changed your mind about the settings you have just done. The default values for the setup items are indicated in bold.

FUNCTIONS

↑

BACK TO MFG: NO

→ or ←

BACK TO MFG: YES

↓ or PROG

PRINT OUT ?

If you want to select BACK TO MFG: YES, you have to exit from this item using the ↑ or the ↓ key, in order to confirm the selection of this value.

At this point, the **Power On Configuration Setup** procedure is finished. If you exit pressing the ↓ and the PROGRAM key, the new settings will be saved.

Do not power off the printer before all data have been written into the NVM and the printer has returned online.

Program Setup

The default values of the various functions are indicated in bold.

Entering the Program Setup

Press the PROGRAM key when the printer is turned on and is offline or online without printing. The following message will be displayed:

PRINT OUT? NO

The figure in the following page shows the structure and how to move inside the Program Setup.

Main Structure

The items define the following functions:

- Print Program Setup with #4
- Handling of the #4
- Print Statistics of the printer
- The direct access to the Power-On Configuration
- Hexadecimal printout

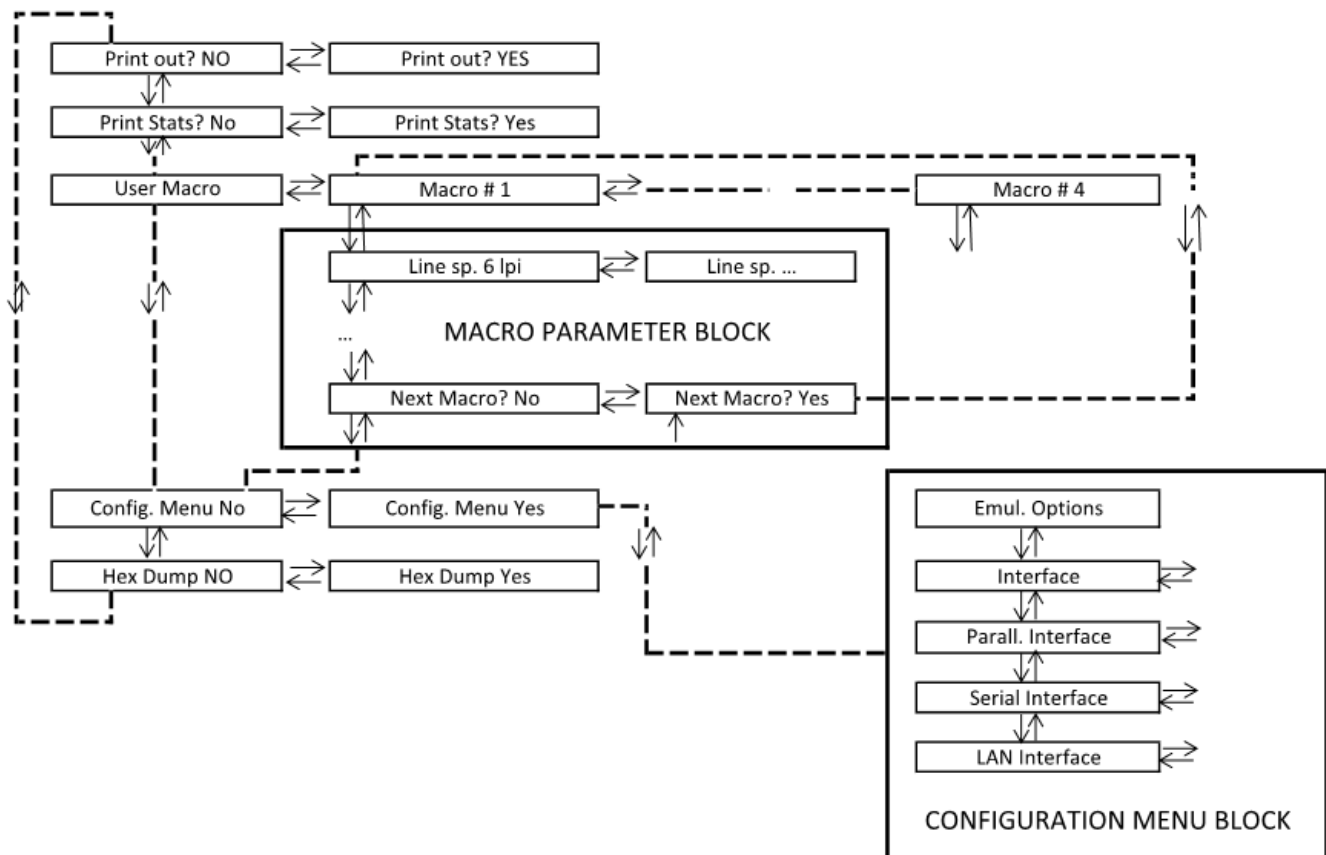

Printout of the Printer Settings

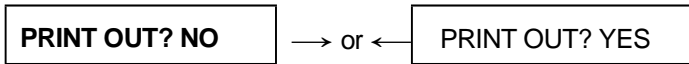

↓
PRINT STATS? NO

- PRINT OUT? NO The setup is not printed.
- PRINT OUT? YES The printer setup is printed. The printout starts as soon as you select this value.

NOTE: The Program setup printout indicates:

- The printer model
- The current firmware release with Version and FW Identifier
- The serial number which can be applied as USB ID
- The MAC ADDRESS of the LAN card
- The currently selected values of the #4 (the current selected macro is marked with the ## symbols (USER MACRO ##))

-PROGRAM SETUP PRINTOUT:							
PRINTER MODEL:	S809						
FIRMWARE CODE:	ver. 1.00 FMW00475						
SERIAL NUMBER:	00000000						
MAC ADDRESS:	00066D211167						
USER MACRO#1#	USER MACRO#1#	USER MACRO#1#	USER MACRO#1#	USER MACRO#1#	USER MACRO#1#	USER MACRO#1#	USER MACRO#1#
-----	-----	-----	-----	-----	-----	-----	-----
LINE SP.	6 LPI	LINE SP.	6 LPI	LINE SP.	6 LPI	LINE SP.	6 LPI
LINE SP. LOCK	NO	LINE SP. LOCK	NO	LINE SP. LOCK	NO	LINE SP. LOCK	NO
LENGTH 66	LINES	LENGTH 66	LINES	LENGTH 66	LINES	LENGTH 66	LINES
TOP OF FORM	0	TOP OF FORM	0	TOP OF FORM	0	TOP OF FORM	0
IGNORE F.F.	NO	IGNORE F.F.	NO	IGNORE F.F.	NO	IGNORE F.F.	NO
SKIPOVER	0	SKIPOVER	0	SKIPOVER	0	SKIPOVER	0
DRAFT MODE	NORM	DRAFT MODE	NORM	DRAFT MODE	NORM	DRAFT MODE	NORM
FONT LOCK	NO	FONT LOCK	NO	FONT LOCK	NO	FONT LOCK	NO
QUALITY	LQ	QUALITY	LQ	QUALITY	LQ	QUALITY	LQ
FONT	DRAFT	FONT	DRAFT	FONT	DRAFT	FONT	DRAFT
PITCH	10 CPI	PITCH	10 CPI	PITCH	10 CPI	PITCH	10 CPI
15&24CPI	NORMAL	15&24CPI	NORMAL	15&24CPI	NORMAL	15&24CPI	NORMAL
PITCH LOCK	NO	PITCH LOCK	NO	PITCH LOCK	NO	PITCH LOCK	NO
LEFT MARGIN	0	LEFT MARGIN	0	LEFT MARGIN	0	LEFT MARGIN	0
RIGHT MARGIN	136	RIGHT MARGIN	136	RIGHT MARGIN	136	RIGHT MARGIN	136
SLASH ZERO	NO	SLASH ZERO	NO	SLASH ZERO	NO	SLASH ZERO	NO
PATH	FRONT 1	PATH	FRONT 1	PATH	FRONT 1	PATH	FRONT 1
TEAR	NORMAL	TEAR	NORMAL	TEAR	NORMAL	TEAR	NORMAL
TEAR DELAY	1	TEAR DELAY	1	TEAR DELAY	1	TEAR DELAY	1
STRONG	IMPACT	STRONG	IMPACT	STRONG	IMPACT	STRONG	IMPACT
PERFOR. SAFE	NO	PERFOR. SAFE	NO	PERFOR. SAFE	NO	PERFOR. SAFE	NO
QUIET PRINT	OFF	QUIET PRINT	OFF	QUIET PRINT	OFF	QUIET PRINT	OFF
AUTOGAP	0	AUTOGAP	0	AUTOGAP	0	AUTOGAP	0
TUNING:HORIZ	0	TUNING:HORIZ	0	TUNING:HORIZ	0	TUNING:HORIZ	0
TUNING:VERT	0	TUNING:VERT	0	TUNING:VERT	0	TUNING:VERT	0
SPACES COMP.	NO	SPACES COMP.	NO	SPACES COMP.	NO	SPACES COMP.	NO

Printout of the Printer Statistics

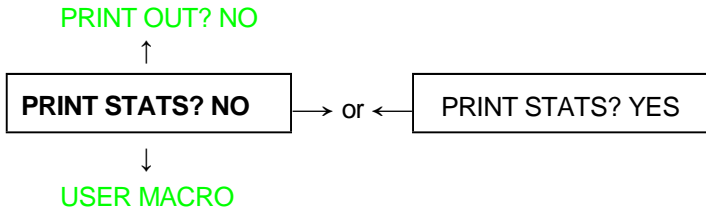

PRINT STATS? NO The printer statistics is not printed.
 PRINT STATS? YES The printer statistics is printed. The printout starts as soon as you select this value.

NOTE: The Printer Statistic printout indicates:

- The printer model
- The current firmware release with Version and FW Identifier
- The statistic parameters :
 - PowerOn Cycle
 - PowerOn Hours
 - Pages
 - Barcodes
 - Pages with Graphics
 - HS Draft Characters
 - Draft Characters
 - Best Draft Characters
 - NLQ Characters
 - LQ Characters

<input type="radio"/>	-USAGE STATISTIC DATA PRINTOUT:	<input type="radio"/>
<input type="radio"/>		<input type="radio"/>
<input type="radio"/>	PRINTER MODEL: S809	<input type="radio"/>
<input type="radio"/>	FIRMWARE CODE: ver. 1.00 FMW00475	<input type="radio"/>
<input type="radio"/>		<input type="radio"/>
<input type="radio"/>		<input type="radio"/>
<input type="radio"/>	PowerOn Cycle:	<input type="radio"/>
<input type="radio"/>	PowerOn Hours: 3	<input type="radio"/>
<input type="radio"/>	Pages: 2	<input type="radio"/>
<input type="radio"/>	BarCodes: 12,348	<input type="radio"/>
<input type="radio"/>	Pages With Graphics: 1,508	<input type="radio"/>
<input type="radio"/>	HS Draft Characters: 25,243,568	<input type="radio"/>
<input type="radio"/>	Draft Characters: 128,909,878	<input type="radio"/>
<input type="radio"/>	BEST Draft Characters: 23,567	<input type="radio"/>
<input type="radio"/>	NLQ Characters: 25,345,678	<input type="radio"/>
<input type="radio"/>	LQ Characters: 78,908	<input type="radio"/>

User Macro

The USER MACRO item allows to prepare four ((or eight depending by the model) printing environments (MACRO#1, MACRO#2, MACRO#3 and MACRO#4). Each macro is composed of a group of parameters which define a configuration that can then be recalled to easily set the printer for four printing environments.

Selection of the User Macro

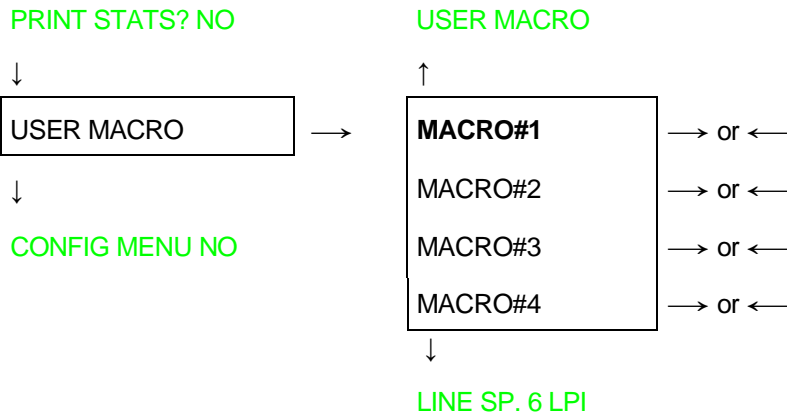

Selection of the macro for which you intend to set the parameters.

When a new macro is selected and the fanfold paper is present in the paper path set in the previous macro, it will be automatically parked (TEAR IF NECESS/PARK PAPER is displayed). Tear off this fanfold paper and press PARK key.

User Macro Parameters

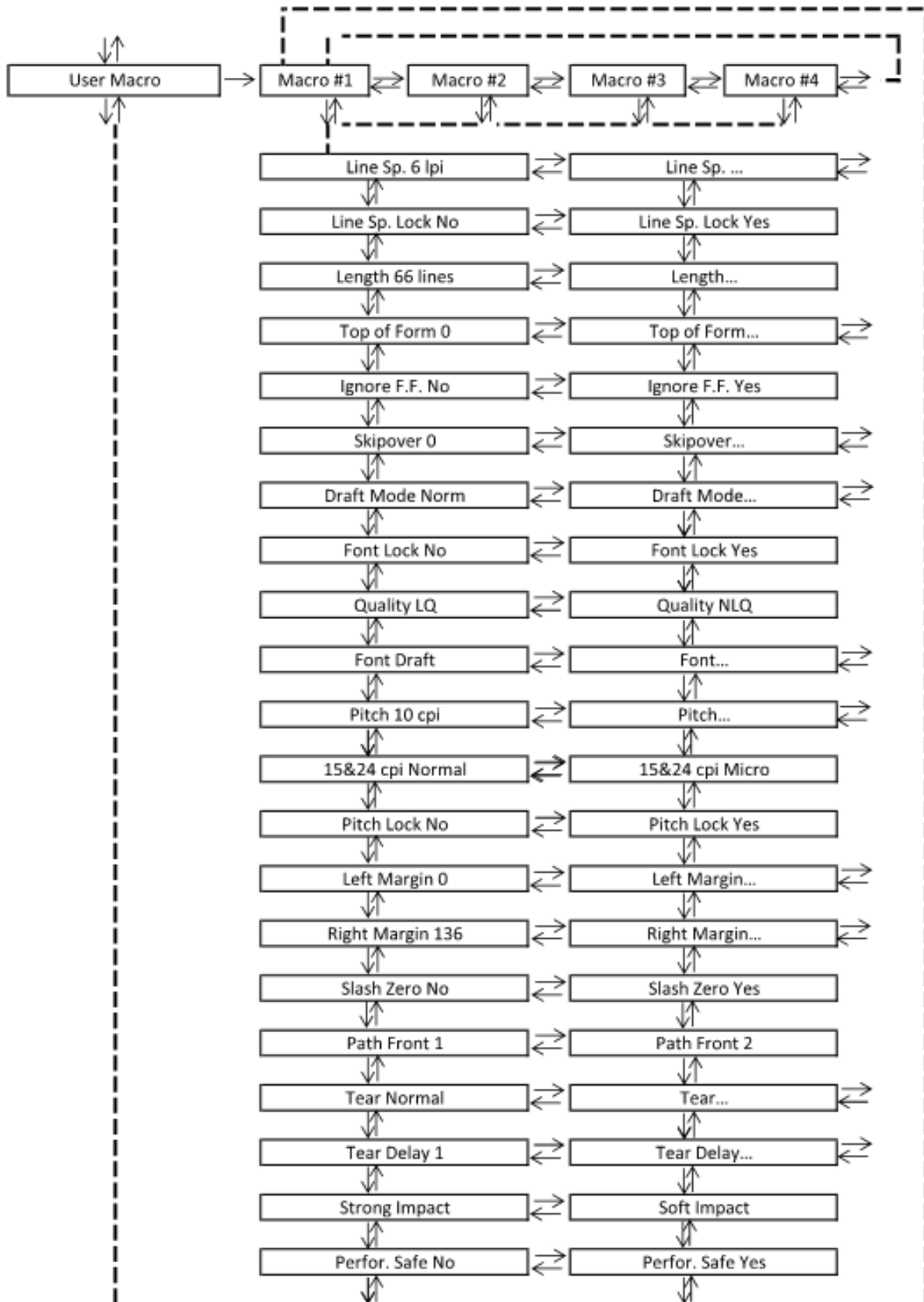

The second part of this table on next page

The first part of this table on previous page

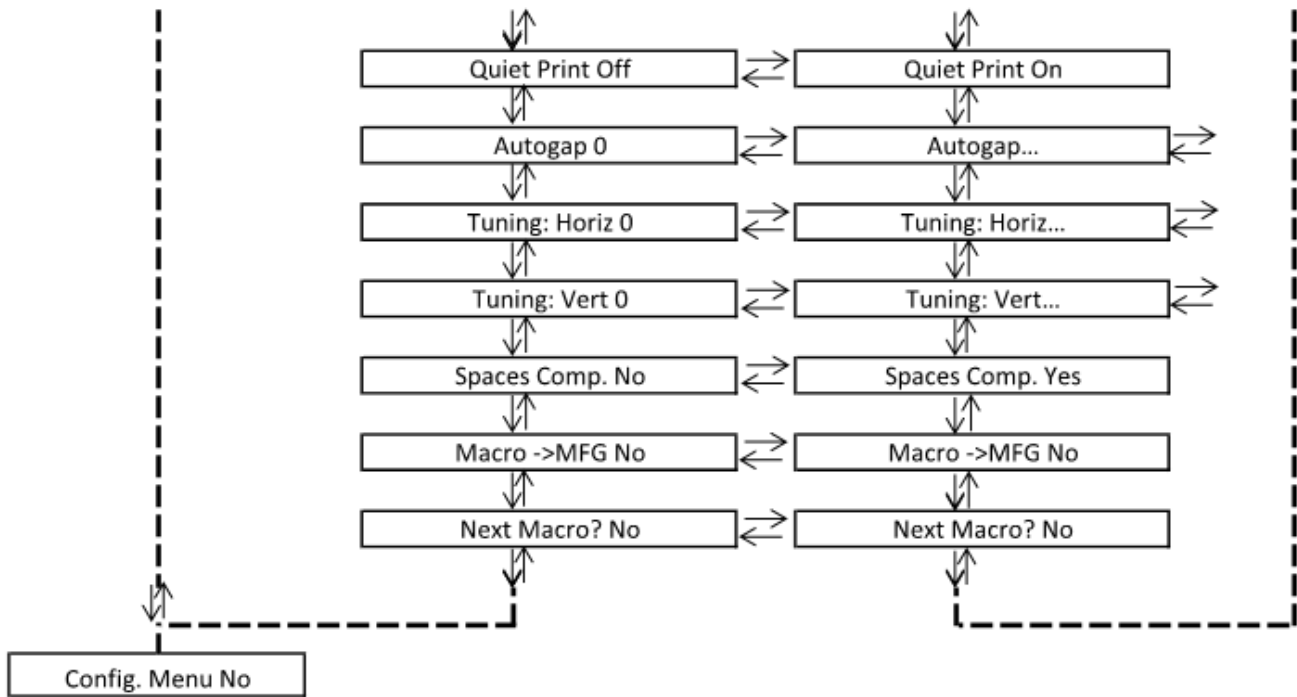

Line Spacing

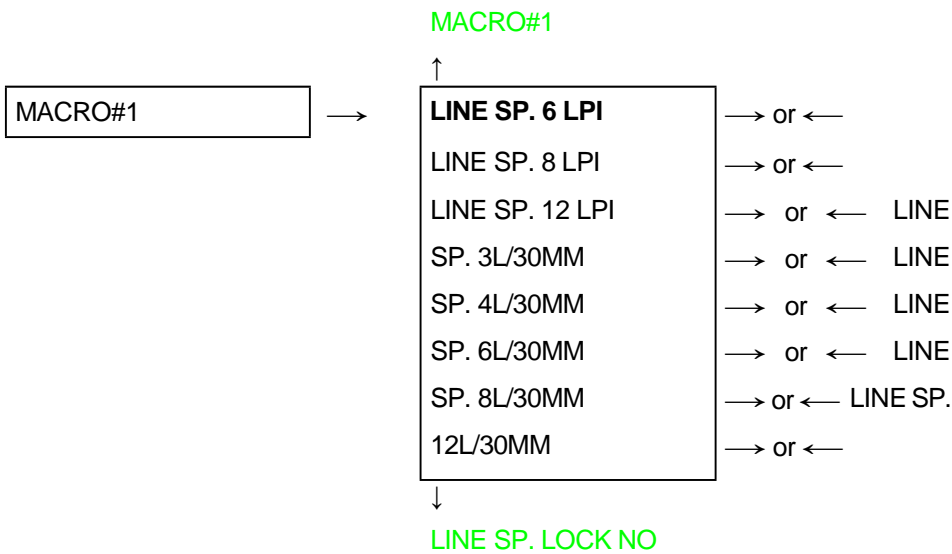

These values define the line spacing in lines/inch (6, 8, 12) or in lines per 30 mm (3, 4, 6, 8, 12).

Line Spacing Lock

LINE SP. 6 LPI

↑

LINE SP. LOCK NO	→ or ←
LINE SP. LOCK YES	→ or ←

↓

LENGTH xxx

LINE SP. LOCK NO	Setting this item, the value set for vertical spacing can be changed by software or operator panel.
LINE SP. LOCK YES	Setting this item, the value set for vertical spacing cannot be changed by software but only by operator panel.

Page Length

LINE SP. LOCK NO

↑

LENGTH 1 LINE	→ or ←
LENGTH ... LINES	→ or ←
LENGTH 244 LINES	→ or ←

↓

TOP OF FORM 0

These items set the page length for fanfold paper in number of lines depending on the current vertical spacing. Default value is **66 lines**.

Top of Form

LENGTH xx

↑

TOP OF FORM 0	→ or ←
TOP OF FORM ...	→ or ←
TOP OF FORM xxx	→ or ←

↓

IGNORE F.F. NO

These items set the top of form. The values range between 0 and the page length - 1.

Form Feed (FF) Command

TOP OF FORM 0

↑

IGNORE F.F. NO	→ or ←
IGNORE F.F. YES	→ or ←

↓

SKIPOVER 0

IGNORE F.F. NO

The Form Feed (FF) command is always executed.

IGNORE F.F. YES

The Form Feed (FF) command is ignored when the paper is in the top of form (TOF) position.
A Form Feed can be performed if the LOAD/FF key is pressed.

Skip Over Perforation

IGNORE F.F. NO

↑

SKIPOVER 0	→ or ←
SKIPOVER ...	→ or ←
SKIPOVER xxx	→ or ←

↓

DRAFT MODE NORM

These items set the skipover perforation. The values range between 0 and the page length - 1.

Draft Print Mode Selection

SKIPOVER 0

↑

DRAFT MODE NORM	→ or ←
DRAFT MODE BEST	→ or ←
DRAFT MODE HS	→ or ←

↓

QUALITY LQ

DRAFT MODE NORM

The printer performs the draft printing at normal speed.

DRAFT MODE BEST

The printer performs the draft printing at low speed to obtain better quality printing.

DRAFT MODE HS

The printer performs the draft printing at high speed.

Font Lock

DRAFT MODE NORM



FONT LOCK NO	→ or ←
FONT LOCK YES	→ or ←



QUALITY LQ

FONT LOCK NO Setting this item, the Font can be changed by software or operator panel.
 FONT LOCK YES Setting this item, the Font can be changed ONLY by operator panel.

Quality Print Mode Selection

DRAFT MODE NORM



QUALITY LQ	→ or ←
QUALITY NLQ	→ or ←



FONT Draft

QUALITY LQ The printer performs the Letter Quality printing.
 QUALITY NLQ The printer performs the Near Letter Quality printing.

Font Selection

QUALITY LQ



FONT Draft	→ or ←
FONT Courier	→ or ←
FONT OCR-B	→ or ←
FONT Gothic	→ or ←
FONT Prestige	→ or ←
FONT Present	→ or ←
FONT OCR-A	→ or ←
FONT Script	→ or ←



PITCH 10 CPI

Selects the fonts. OCR-A is displayed only if a not proportional pitch has been selected.

DBCS Font Selection

QUALITY LQ



DBCS Draft	→ or ←
DBCS NLQ	→ or ←
DBCS LQ	→ or ←
DBCS HDQ	→ or ←
DBCS SSQ	→ or ←
FONT HSQ	→ or ←

PITCH 10 CPI

Note: This menu item is only shown on the printer with the DBCS feature installed and set the print mode.

Pitch Selection

FONT Draft



PITCH 5 CPI	→ or ←
PITCH 6 CPI	→ or ←
PITCH 7.5 CPI	→ or ←
PITCH 8.5 CPI	→ or ←
PITCH 10 CPI	→ or ←
PITCH 12 CPI	→ or ←
PITCH 15 CPI	→ or ←
PITCH 17.1 CPI	→ or ←
PITCH 20 CPI	→ or ←
PITCH 24 CPI	→ or ←
PITCH PROP	→ or ←



15&24CPI NORMAL

These items set the horizontal spacing in characters per inch. The PITCH PROP item sets proportional character spacing.

DBCS Pitch Selection

FONT Draft



PITCH 6.7 CPI	→ or ←
PITCH 7.5 CPI	→ or ←
PITCH 5 CPI	→ or ←
PITCH 6 CPI	→ or ←



15&24CPI NORMAL

Note: This menu item is only shown on the printer with the DBCS feature installed and set the horizontal spacing in characters per inch.

Micro Dot Print Mode

PITCH 10 CPI

↑

15&24CPI NORMAL

→ or ←

15&24CPI MICRO

→ or ←

↓

PITCH LOCK NO

15&24CPI MICRO

The print matrix uses 8 x 8 dots only if the horizontal spacing is 15 or 24 cpi (micro mode).

15&24CPI NORMAL

The print matrix uses 12 x12 dots (normal mode).

Pitch Lock

15&24CPI NORMAL

↑

PITCH LOCK NO

→ or ←

PITCH LOCK YES

→ or ←

↓

LEFT MARGIN 0

PITCH LOCK NO

Setting this item, the pitch can be changed by software or operator panel.

PITCH LOCK YES

Setting this item, the pitch can be changed ONLY by operator panel.

Left Margin

PITCH LOCK NO

↑

LEFT MARGIN 0

→ or ←

LEFT MARGIN ...

→ or ←

LEFT MARGIN xxx

→ or ←

↓

RIGHT MARGIN 136

The Left Margin is set in number of columns (depending on the current pitch) starting from the physical left edge.

Right Margin

LEFT MARGIN 0

↑

RIGHT MARGIN. 2	→ or ←
RIGHT MARGIN. ...	→ or ←
RIGHT MARGIN. xxx	→ or ←

↓

SLASH ZERO NO

The Right Margin is set in number of columns (depending on the current pitch) starting from the physical left edge. The default value is **136**.

Zero Character Printing

RIGHT MARGIN 136

↑

SLASH ZERO NO	→ or ←
SLASH ZERO YES	→ or ←

↓

PATH FRONT 1

You can select the Zero character printing with or without a slash.

Paper Path Selection

This function defines the default paper path for the current macro. Paper Path selection depends upon the printer model and the installed options.

SLASH ZERO NO

↑

PATH FRONT 1	→ or ←
PATH FRONT 2	→ or ←

↓

TEAR NORMAL

PATH FRONT 1

Paper loading with the Front1 push tractor (low position).

PATH FRONT 2

Paper loading with the Front2 push tractor (up position). This item is displayed only if the Front2 push tractor option is installed.

Tear-Off Mode

PATH FRONT 1

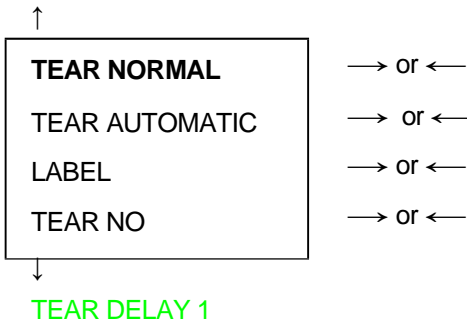

- TEAR NORMAL The Tear-Off Function is performed pressing the TEAR key when the printer is offline.
- TEAR AUTOMATIC When the printer is not receiving any data, the paper is moved to the Tear-Off position. It is returned to the Tear-Off position as soon as it receives printing data.
- LABELS This item must be set when printing on labels, in order to avoid paper jams.
- TEAR NO The paper does not execute any backward movement. When pressing the PARK key, the paper is ejected.
- TEAR NO The paper does not execute any backward movement.

See also “How to Use the Tear-Off Function ” and “How to Handle the Paper Parking ” later in this chapter

Tear Delay Mode

TEAR NORMAL

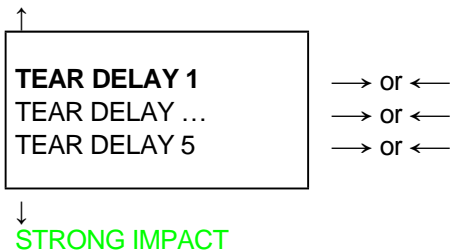

This item defines the time that printer uses to move paper to the Tear-Off position in automatic tear mode. The range of the tear delay is between 1 and 5 seconds. The default value is 1 sec.

Print Impact Strength

TEAR DELAY 1



- STRONG IMPACT The impact strength of the print head is set for printing on multicopy paper.
- SOFT IMPACT The impact strength of the print head is set for printing few copies. The printing noise is reduced.

Paper Perforation

This function allows to move the print head aside the paper when the fanfold paper perforation passes between the mylar and the print bar, to facilitate paper movement on critical forms.

STRONG IMPACT

↑

PERFOR. SAFE NO
PERFOR. SAFE YES

→ or ←

→ or ←

↓

QUIET PRINT OFF

PERFOR. SAFE NO

The function is disabled. The print head remains in its position, when the perforation of the paper passes.

PERFOR. SAFE YES

The function is enabled. The print head is moved aside, when the perforation passes.

Quiet Printing

PERFOR. SAFE NO

↑

QUIET PRINT OFF
QUIET PRINT ON

→ or ←

→ or ←

↓

AUTOGAP 0

QUIET PRINT OFF

The function is disabled. Printing at normal noise level.

QUIET PRINT ON

The function is enabled. Printing at reduced noise level.

Adjusting the Distance of the Print Head

QUIET PRINT OFF

↑

AUTOGAP -5
AUTOGAP ...
AUTOGAP +3
MANUAL GAP
FIXED GAP 0.3
FIXED GAP ...
FIXED GAP 9.3

→ or ←

→ or ←

→ or ←

→ or ←

→ or ←

→ or ←

→ or ←

↓

TUNING: HORIZ 0

AUTOGAP xxx

Selecting one of these values sensing the paper thickness. Negative values reduce the distance between the print head and the paper. Default value is AUTOGAP 0.

MANUAL GAP

Selecting this item, the print head must be adjusted manually.

FIXED GAP xxx

Selecting one of these values the printer adjusts the print head gap to a fixed distance.

Horizontal Character Tuning

AUTOGAP 0

↑

TUNING: HORIZ 0	→ or ←
TUNING: HORIZ ...	→ or ←
TUNING: HORIZ 60	→ or ←

↓

TUNING: VERT 0

These values adjust the distance between the left paper margin and the first print character. The values correspond to 1/120 inch units, i.e. the tuning ranges between 0 and 0.5 inch.

Vertical Character Tuning

TUNING: HORIZ 0

↑

TUNING: VERT. -30	→ or ←
TUNING: VERT. ...	→ or ←
TUNING: VERT. 360	→ or ←

↓

SPACE COMP. NO

These values adjust the distance between the top paper margin and the first printable line. The values correspond to 1/180 inch units, i.e. the tuning ranges between -1/6 and 2 inch. **0** is the default value.

Space Compression

TUNING: VERT 0

↑

SPACE COMPR. YES	→ or ←
SPACE COMPR. NO	→ or ←

↓

MACRO -> MFG NO

This setting if YES compress the space characters.

Resetting the Macro Parameters to the Factory Defaults

TUNING: VERT. 0

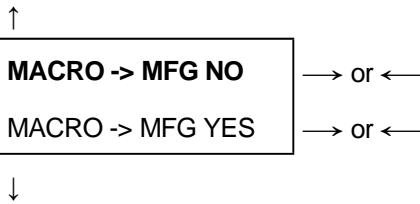

NEXT MACRO? NO

MACRO -> MFG NO The new values set for the macro parameters will be the used.
 MACRO -> MFG YES The values set for the macro parameters will be reset to their factory defaults.

Selecting Another Macro

MACRO -> MFG NO

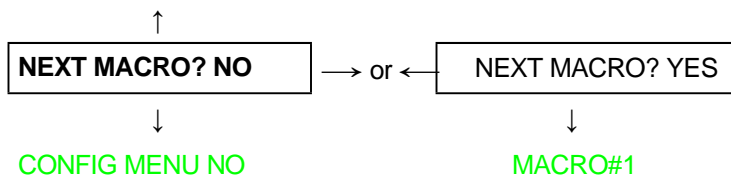

To pass over to another macro, select NEXT MACRO YES. Pressing the ↓ or ↑ key the item MACRO#1 is displayed, then press the → key to pass over to MACRO#2 (MACRO CHANGING is displayed).

When passing over from one macro to another, the fanfold paper loaded from the paper path, selected in the previous macro, will be automatically parked (TEAR IF NECESS/PARK PAPER is displayed). Tear off this fanfold paper and press PARK key

You can now set the parameters for MACRO#2 as described above. In this way you prepare the second printing environment. Passing over from one macro to the other then sets two different printing environments.

Passing over to the Power-On Configuration

At this point of the setup, it is possible to pass over to the *Power On Configuration* functions setting. See the specific chapter for detailed item.

NEXT MACRO NO

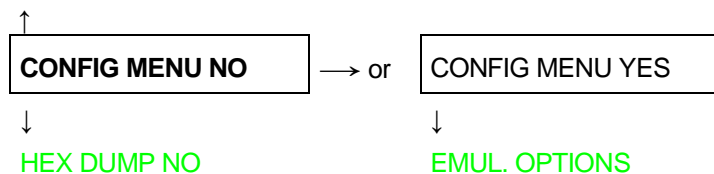

These items are self-explaining.

Hexadecimal Dump

CONFIG MENU NO

↑

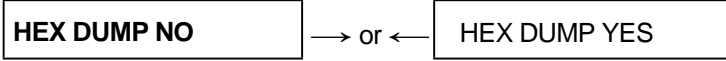

↓

STORE? QUIT

If you select HEX DUMP YES, press the PROGRAM key to set this item. The hexadecimal printing continues, until the DUMP

entering the Setup.

HEX NO item is selected, again into Program

○	This is an example of HEXDUMP printout.															○								
○	Numbers: 123456789															○								
○	Upper case characters ABCDEFGHIJKLMNOPQRSTUVWXYZ															○								
○	Lower case characters abcdefghijklmnopqrstuvwxyz															○								
○	eof															○								
○	0000	54	68	69	73	20	69	73	20	61	6E	20	65	78	61	6D	70	This is an examp			○			
○	0001	6C	65	20	6F	66	20	48	45	58	44	55	4D	50	20	70	72	le of HEXDUMP pr			○			
○	0002	69	6E	74	6F	75	74	2E	0D	0A	0D	0A	4E	75	5D	62	65	intout. # # Numbe			○			
○	0003	72	73	3A	20	20	20	20	20	20	20	20	20	20	20	20	20	rs:			○			
○	0004	20	20	30	31	32	33	34	35	36	37	38	39	0D	0A	55	70	123456789 # # Up			○			
○	0005	70	65	72	20	63	51	73	65	20	63	58	61	72	61	63	74	per case charact			○			
○	0006	65	72	73	3A	20	41	42	43	44	45	46	47	48	49	4A	4B	ers: ABCDEFGHIJK			○			
○	0007	4C	4D	4E	4F	50	51	52	53	54	55	56	57	58	59	5A	0D	LMNOPQRSTUVWXYZ			○			
○	0008	0A	4C	6E	77	65	72	20	63	61	73	65	20	63	68	61	72	# # Lower case char			○			
○	0009	61	65	74	65	72	73	3A	20	61	62	63	64	66	66	67	68	acters: abcdefgh			○			
○	000A	69	6A	6B	6C	6D	6E	6F	70	71	72	73	74	75	76	77	78	ijklmnopqrstuvw			○			
○	000B	79	7A	0D	0A	65	6F	66	0D	0A											yz # # eof # #			○

Storing the values

HEX DUMP NO

↑

STORE? QUIT	→ or ←
STORE? SAVE	→ or ←
STORE? CURRENT	→ or ←

PROG

EXIT

STORE? QUIT	This setting does not save any of the new values set. The values set previously will be used.
STORE? SAVE	The values set are stored permanently (in the NVM) and will be used until they are changed by the operator.
STORE? CURRENT	The values set are valid until the printer is turned off. When you turn the printer on again, the values set in the preceding setup will be used.

At this point the Program Configuration Setup is finished
You exit pressing the PROGRAM key

ANSI Emulation

The following items appear only when the ANSI emulation has been selected.

ANSI Character Sets

EMULATION ANSI

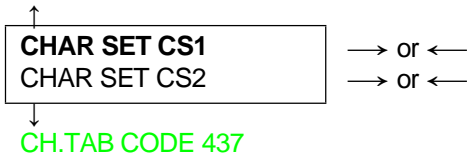

- CHAR SET CS1 The printer uses the CS1 character set.
- CHAR SET CS2 The printer uses the CS2 character set.

ANSI Code Pages

CHAR. SET CS2

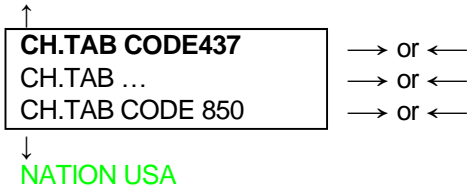

The following code pages are available:

CODE 437	CODE 850	CODE 851	CODE 852	CODE 853	CODE 855	CODE 858	CODE 860
CODE 863	CODE 864	CODE 865	CODE 866	CODE 867	ISO 1	ISO 2	ISO 3
ISO 4	ISO 5	ISO 6	ISO 7	ISO 8	ISO 9	ISO 15	MAZOWIA
TURKISH	CP 437G	ROMAN-8	KAMENICKY	CWI	IN2	CODE 864E	CP1250
CP 1251	CP 1252	CP 1253	CP 1254	CP 1255	CP 1256	CP 1257	BULGAR

ANSI Code Pages

CH.TAB.. CODE437

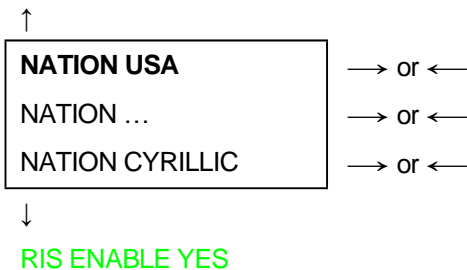

The following code pages are available:

USA	GERMANY	FRANCE A	FRANCE B	FREN/CANA	DUTCH	ITALY	UK
SPAIN	DAN/NOR A	DAN/NOR B	DAN/NOR C	DAN/NOR D	SWE/FIN A	SWE/FIN B	SWE/FIN C
SWE/FIN D	SWISS	YUGOSLAV	UK A	TURKEY	GREEK	CYRILLIC	

Reset Enable

NATION USA

↑

RIS ENABLE YES	→ or ←
RIS ENABLE NO	→ or ←

↓

RIS ENABLE YES

If the printer receives a command (ESC c) from the host to reset the printer, then the printer will (YES) or will not (NO) reset the current configuration to the power-up configuration.

SI/SO Control

RIS ENABLE YES

↑

SI/SO CTL YES	→ or ←
SI/SO CTL NO	→ or ←

↓

AUTO CR YES

If the printer receives a command (SI or SO) from the host to enable or disable the special modes (oversize, expanded and bar code modes), then the printer will (YES) or will not (NO) respond to the <SI> and <SO> commands based upon your selection.

Auto Carriage Return

SI/SO CTL YES

↑

AUTO CR YES	→ or ←
AUTO CR NO	→ or ←

↓

PRIME ON DEL YES

If the printer receives a command (LF) from the host to perform a line feed then the printer will (YES) or will not (NO) append a carriage return based upon your selection.

Prime on Delete

AUTO CR YES

↑

PRIME ON DEL YES	→ or ←
PRIME ON DEL NO	→ or ←

↓

CONTRL IN DG YES

If the printer receives a command (DEL) from the host, then the printer will (YES) or will not (NO) perform a prime (reset) based upon your selection.

Control Codes in Dot Graphics

PRIME ON DEL YES

↑

CONTRL IN DG YES	→ or ←
CONTRL IN DG NO	→ or ←

↓

CONTRL IN DG YES

If the printer receives a control code from the host while in dot graphics mode, then the printer will (YES) or will not (NO) respond to the particular control code based upon your selection.

Vertical Expansion

CONTRL IN DG YES

↑

EXPAND UP YES	→ or ←
EXPAND UP NO	→ or ←

↓

ALT GRAPHICS YES

This setting defines the vertical expansion from the baseline up (YES) or from the top line down (NO).

ALT Graphics

EXPAND UP YES

↑

ALT GRAPHICS YES	→ or ←
ALT GRAPHICS NO	→ or ←

↓

8 BIT CTRL YES

If is selected N: the 6-bit graphics horizontal densities are multiplies of 72.

If is selected Y: the 6-bit graphics horizontal densities are multiplies of 60.

8-bit Control

ALT GRAPHICS YES

↑

8 BIT CTRL YES	→ or ←
8 BIT CTRL NO	→ or ←

↓

S/SUB SCRIPT YES

If the printer receives a control code command (80H to 9FH) whose eighth data bit is set, and the character set is selected, then the printer will (YES) or will not (NO) respond to the particular code based upon your selection.

Superscript/Subscript Character Enable

8 BIT CTRL YES

↑

S/SUB SCRIPT YES	→ or ←
S/SUB SCRIPT NO	→ or ←

↓

ESC+CTR CODE YES

The printer will (YES) or will not (NO) respond to ESC [2 m and ESC [3 m commands.

ESC+Control Code

S/SUB SCRIPT YES

↑

ESC+ CTR CODE YES	→ or ←
ESC+ CTR CODE NO	→ or ←

↓

VT NOT SET YES

In this setting the control codes embedded within escape sequence are valid (YES) or ignored (NO). In both cases, the escape sequence will be valid.

VT Code

ESC+ CTR CODE YES

↑

VT NOT SET YES	→ or ←
VT NOT SET NO	→ or ←

↓

DOUBLE LF YES

In this setting the VT code received without tab set will yield line feed (YES) or will be ignored (NO).

Double Line Feed

VT NOT SET YES

↑

DOUBLE LF YES	→ or ←
DOUBLE LF NO	→ or ←

↓

DOUBLE LF YES

If the printer receives a command (LF) from the host to execute a line feed, then the printer will (Y) or will not (N) also perform double line feed based upon your selection.

Automatic Wrap

DOUBLE LF YES

↑

AUTO WRAP YES	→ or ←
AUTO WRAP NO	→ or ←

↓

CLEAR MARGIN YES

If the printer receives printable data from the host, and such data exceeds the current line length (right margin), then the printer will (Y) or will not (N) continue to print the remaining data on the following line based upon your selection.

If you disable auto wrap by selecting N, then the data beyond the right margin is discarded up to the next line terminator.

Clear Margin

AUTO WRAP YES

↑

CLEAR MARGIN YES	→ or ←
CLEAR MARGIN NO	→ or ←

↓

BACKUP NONE

Clears (Y) or preserves (N) top and bottom margins on form length changes.

Backup Option

CLEAR MARGIN YES

↑

BACKUP NONE	→ or ←
BACKUP BC	→ or ←
BACKUP OS	→ or ←
BACKUP BOTH	→ or ←

↓

GUARD BAR YES

- | | |
|------|--|
| BC | The printer will return the print head to the vertical position established before turning on Barcode modes at the completion of printing of the current barcode symbol. |
| OS | The printer will return the print head to the vertical position established before turning on Oversize modes at the completion of printing of the current barcode symbol. |
| BOTH | The printer will return the print head to the vertical position established before turning on both Barcode and Oversize modes at the completion of printing of the current barcode symbol. |
| NONE | The print head will remain in the vertical and horizontal position active at the completion of printing of the selected symbol. |

Barcode Guard Bar Enable

BACKUP NONE

↑

GUARD BAR YES

→ or ←

GUARD BAR NO

→ or ←

↓

FONT LOCK

The printer will (Y) or will not (N) include left, right and center Guard bars of the barcode styles which use Guard bars based upon your selection. The Guard bars extend into the human readable line of the barcode symbol when it is enabled.

DEC Emulation

When the DEC PPL2 emulation is selected, the following item will be access in the Power-on Configuration Setup and in The Program Setup (Macro):

GO Character Set

EMULATION ANSI

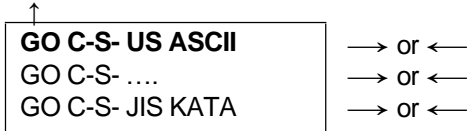

UP C-S DEC SUPP

US ASCII US ASCII	BRITISH British	FINNISH DEC Finnish	FRENCH French
FR/CAN DEC French-Canadian	GERMAN German	ISO ITAL ISO Italian	JIS ROM JIS Roman
DNOR/DAN DEC Norwegian/Danish	ISO SPAN ISO Spanish	SWEDISH DEC Swedish	NOR/DAN Norwegian/Danish
DUTCH DEC Dutch	SWISS DEC Swiss	PORTUG DEC Portuguese	LEGAL Legal
DEC SUPP DEC Supplemental	SPE. GRA DEC Special Graphics	TECHNICAL DEC Technical	7BIT HEB DEC 7-Bit Hebrew
HEBR. SUP DEC Hebrew Supplemental	8 BIT GRES DEC 8-Bit Greek Supplemental	7 BIT TUR DEC 7-Bit Turkish	8 BIT TURS DEC 8-Bit Turkish Supplemental
JIS KATA JIS Katakana			

User Preference Supplemental Character Set

UP C-S DEC SUPP

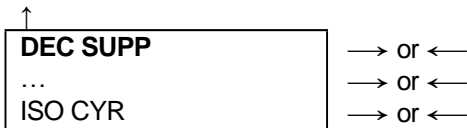

FONT LOCK

The following code pages are available:

DEC SUPP DEC Supplemental	SPEC GRA DEC Special Graphics	TECHNICAL DEC Technical
7 BIT HEB DEC 7-Bit Hebrew	HEBR SUP DEC Hebrew Supplemental	8 BIT GRES DEC 8-Bit Greek Supplemental
7 BIT TUR DEC 7-Bit Turkish	8 BIT TURS DEC 8-Bit Turkish Supplemental	JIS KATA JIS Katakana
ISO LA-1S ISO Latin-1 Supplemental	ISO LA-2S ISO Latin-2 Supplemental	ISO LA-5S ISO Latin-5 Supplemental
ISO LA-9S ISO Latin-9 Supplemental	ISO HEBS ISO Latin-Hebrew Supplemental	ISO LAGRS ISO Latin-Greek Supplemental
ISO CYRS Latin-Cyrillic Supplemental		

Autowrap

AUTO CR YES

↑

AUTO WRAP YES	→ or ←
AUTO WRAP NO	→ or ←

↓

PITCH 10 CPI

AUTOWRAP YES
AUTOWRAP NO

Setting this item, the data over the right margin setting are discharged.
Setting this item, the data over the right margin setting are automatically printed in the next line.

Pitch Selection

AUTO WRAP YES

↑

PITCH 5 CPI	→ or ←
PITCH 6 CPI	→ or ←
PITCH 6.6 CPI	→ or ←
PITCH 7.5 CPI	→ or ←
PITCH 8.2 CPI	→ or ←
PITCH 8.5 CPI	→ or ←
PITCH 9 CPI	→ or ←
PITCH 10 CPI	→ or ←
PITCH 12 CPI	→ or ←
PITCH 13,2 CPI	→ or ←
PITCH 15 CPI	→ or ←
PITCH 16.5 CPI	→ or ←
PITCH 17.1 CPI	→ or ←
PITCH 18 CPI	→ or ←
PITCH 20 CPI	→ or ←
PITCH 24 CPI	→ or ←
PITCH PROP CPI	→ or ←

↓

QUALITY LQ

These items set the horizontal spacing in characters per inch.
PITCH can assume all the additional values, selectable only when DEC PPL2 emulation is active.

Line Spacing

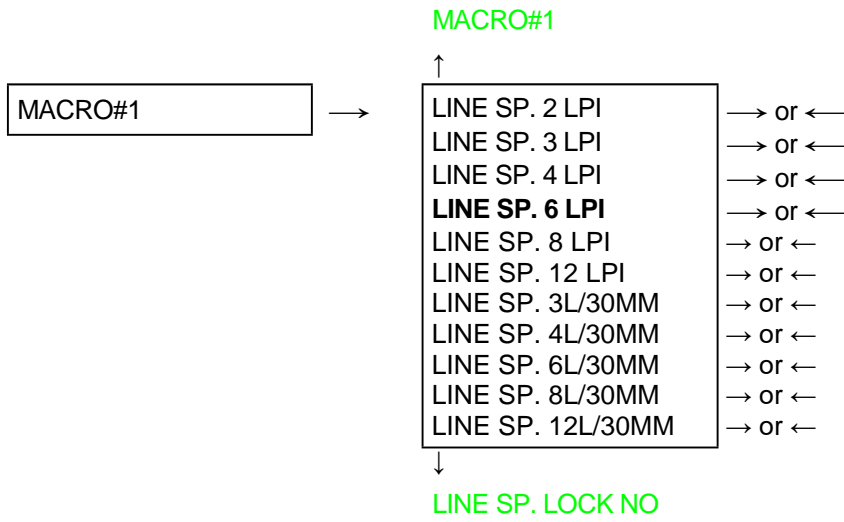

These values define the line spacing in lines/inch (2, 3, 4, 6, 8, 12) or in lines per 30 mm (3, 4, 6, 8, 12).

How to Select the Paper Path

The paper can be loaded into the printer using different paper paths. The messages indicating the paper paths are shown depending upon the printer model and if the corresponding loading device is installed on the printer.

Proceed as follows:

1. Press the ON LINE key to put the printer offline (ON LINE indicator unlit).
2. Press the PATH key, according to the installed devices the following messages are displayed:

PATH FRONT 1 For the paper path using the Front1 push tractor.

PATH FRONT 2 For the paper path using the Front2 push tractor option.

- To load fanfold paper go to "Loading Paper Using the Front1 Push Tractor", "Loading Paper Using the Front2 Push Tractor (option)". When a new paper path is selected, the paper loaded in the printer is automatically parked.

How to Use the Tear-Off Function

This function is used to match the paper perforation with the tear-off bar. For this function the following values must be set:

Selection of the Paper Size

1. Press the PROGRAM key when the printer is disabled or enabled without printing to enter the *Program Setup*.
2. Press the ↓ key and the following message appears:

USER MACRO

3. Press the → key to select the macro for which you want to set the paper size (MACRO#1, MACRO#2, MACRO#3 or MACRO#4).

4. Once the desired macro is displayed press the ↓ key until the following parameter is displayed:

LENGTH xx

5. Press the → or ← key until the desired page size is displayed.
6. Press again the PROGRAM key to exit the setup and set the new value.

Adjusting the Tear-Off Position

To check the Tear-Off Position proceed as follows:

1. Check if the paper perforation matches the tear-off bar on the printer.
2. To move manually the paper to the Tear-Off position, press the TEAR key when the printer is enabled without printing (TEAR NORMAL function selected YES in the *Program Setup*).

You can leave the manual tear off function by pressing again the TEAR key

If it does not:

1. Turn the printer off and press the PROGRAM key and hold it pressed while powering on the printer until the RELEASE KEYS message is displayed to enter the *Power-On Configuration*.
2. Press the ↓ key until the following message appears:

FUNCTIONS

3. Press the → key to enter and then press the ↓ until the following message is displayed:

TEAR ADJUST xxx

4. Press the → or ← key to scroll the values of this function.

Values below 0 move the tear-off position downwards, values above 0 move the paper upwards. The values can be set between +30 and -390 at 1/180 inches (from +1/6 to -13/6 inches).

5. When the desired value is displayed, press the PROGRAM key.
6. Press the PROGRAM key to save and exit from the setup.

Selection of the Tear-Off Mode

It is now possible to select the Tear-Off Mode.

1. Press the PROGRAM key when the printer is disabled or enabled without printing to enter the *Program Setup*.
2. Press the ↓ key. The following message is displayed:

USER MACRO

3. Press the → key to select the macro for which you want to set the tear-off mode (MACRO#1, MACRO#2, MACRO#3 or MACRO#4).
4. Press the ↓ key, until the following message is displayed:

TEAR NORMAL

Pressing the → or ← key it is now possible to decide how to execute the tear off function:

- | | |
|----------------|---|
| TEAR NORMAL | Pressing the TEAR key the paper is moved to the tear-off position.
Pressing again the TEAR key to exit from the tear-off mode, the paper is moved to the printing position. |
| TEAR AUTOMATIC | If the printer is not receiving data, the paper is moved automatically to the tear position. |
| LABEL | The TEAR key is disabled for the tear-off function. This selection is useful when printing on labels. Pressing the PARK key, the printer ejects the paper toward the back of the printer. |
| TEAR NO | The tear-off function is disabled. |

5. Press the PROGRAM key to exit the setup.

How to Lock/Unlock the Printer Setups

To prevent not expertise persons changing the printer setup parameters, it is possible to lock/unlock the access to the printer setups as follows:

- Press ON LINE, MACRO and TEAR keys at the same time and keep them pressed while powering the printer on until the display shows RELEASE KEYSmessage. As soon as these keys are released, the following messages will be displayed:

	STARTING UP
then	S809 Ver. Xx.x
then	LOCKED MENU

Now the access to the printer setups is locked. If the PROGRAM key is pressed, the LOCKED MENU message is displayed (the PROGRAM key is disabled).

- If you decide to unlock the printer setup, turn the printer off, then press the ON LINE, MACRO and TEAR keys at the same time and keep them pressed while powering the printer on again until the display shows RELEASE KEYSmessage. As soon as these keys are released, the following messages will be displayed:

	STARTING UP
then	S809 Ver. Xx.x
then	UNLOCKED MENU

How to Handle the Paper Parking

According to the setting of the TEARitem in the *Program Setup*, the paper parking procedure is performed in different ways. See the following description:

If TEAR NO is selected:

- When the paper is positioned at the first printable line and the paper path is changed (changing the Macro or pressing the PATH key) or the PARK key is pressed, the printer performs automatically the parking procedure.
- If at least one line has been printed, or the paper has been fed forward at least 1 line and the paper path is changed (changing the Macro or pressing the PATH key) or the PARK key is pressed, the display shows **TEAR IF NECESS./PARK PAPER**.
If the paper to be parked is longer than 18" tear it off and press the PARK key again to perform the parking procedure.

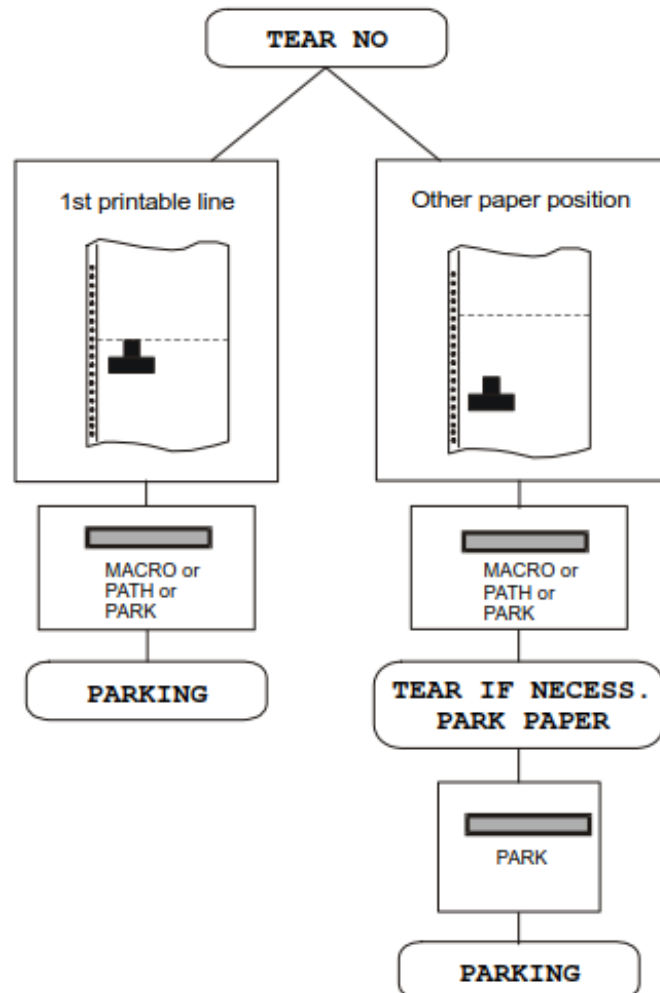

If TEAR NORMAL is selected:

- When the paper is positioned at the first printable line and the paper path is changed (changing the Macro or pressing the PATH key) or the PARK key is pressed, the printer performs automatically the parking procedure.
- If at least one line has been printed, or the paper has been fed forward at least 1 line and the paper path is changed (changing the Macro or pressing the PATH key) or the PARK key is pressed, the paper is moved to the tear-off position and the display shows **TEAR IF NECESS./PARK PAPER**. If the paper to be parked is longer than 18" tear it off and press the PARK key again to perform the parking procedure.
- When the paper is positioned in the tear-off position after pressing the TEAR key, if you press the PARK key the printer performs automatically the parking procedure.

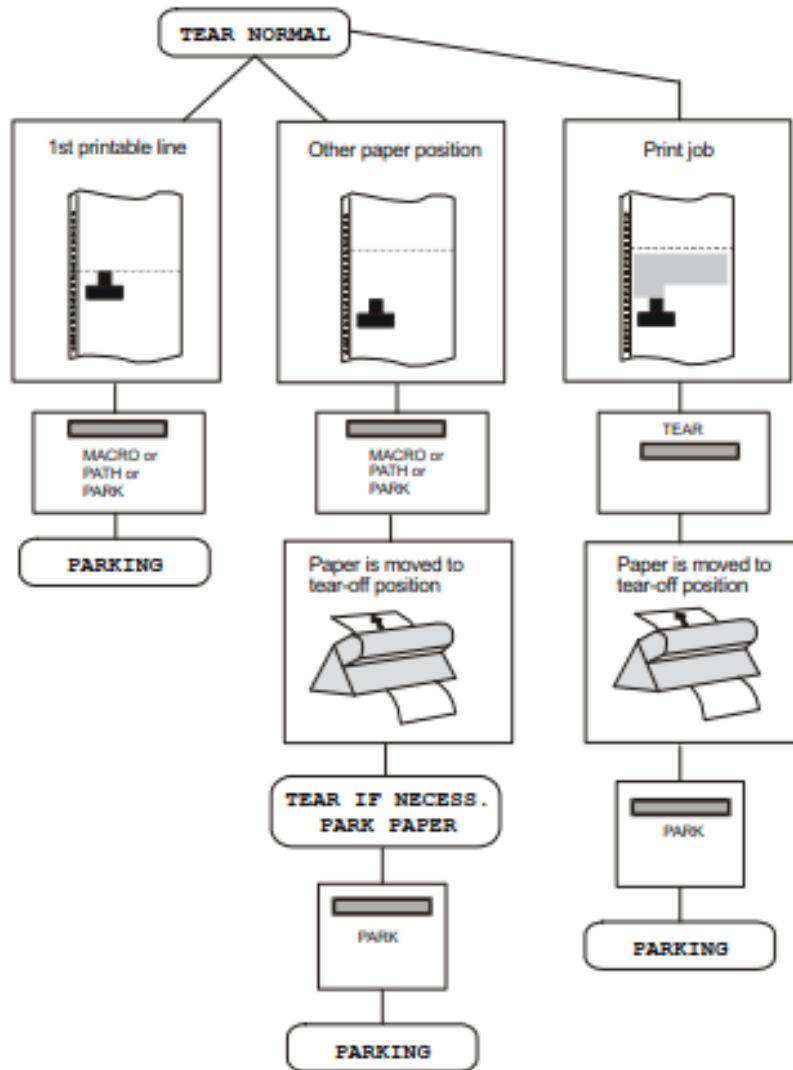

If TEAR AUTOMATIC is selected:

- When the paper is positioned at the first printable line and the paper path is changed (changing the Macro or pressing the PATH key) or the PARK key is pressed, the printer performs automatically the parking procedure.
- If at least one line has been printed, or the paper has been fed forward at least 1 line and the paper path is changed (changing the Macro or pressing the PATH key) or the PARK key is pressed, the paper is moved to the tear position, the display shows **TEAR IF NECESS./ PARK PAPER**. If the paper to be parked is longer than 18" tear it off and press the PARK key again to perform the parking procedure.
 -
- If at least one line has been printed, or the paper has been fed forward at least 1 line and the paper path is changed (changing the Macro or pressing the PATH key) or the PARK key is pressed when the paper is already in the tear position, the printer performs automatically the parking procedure.

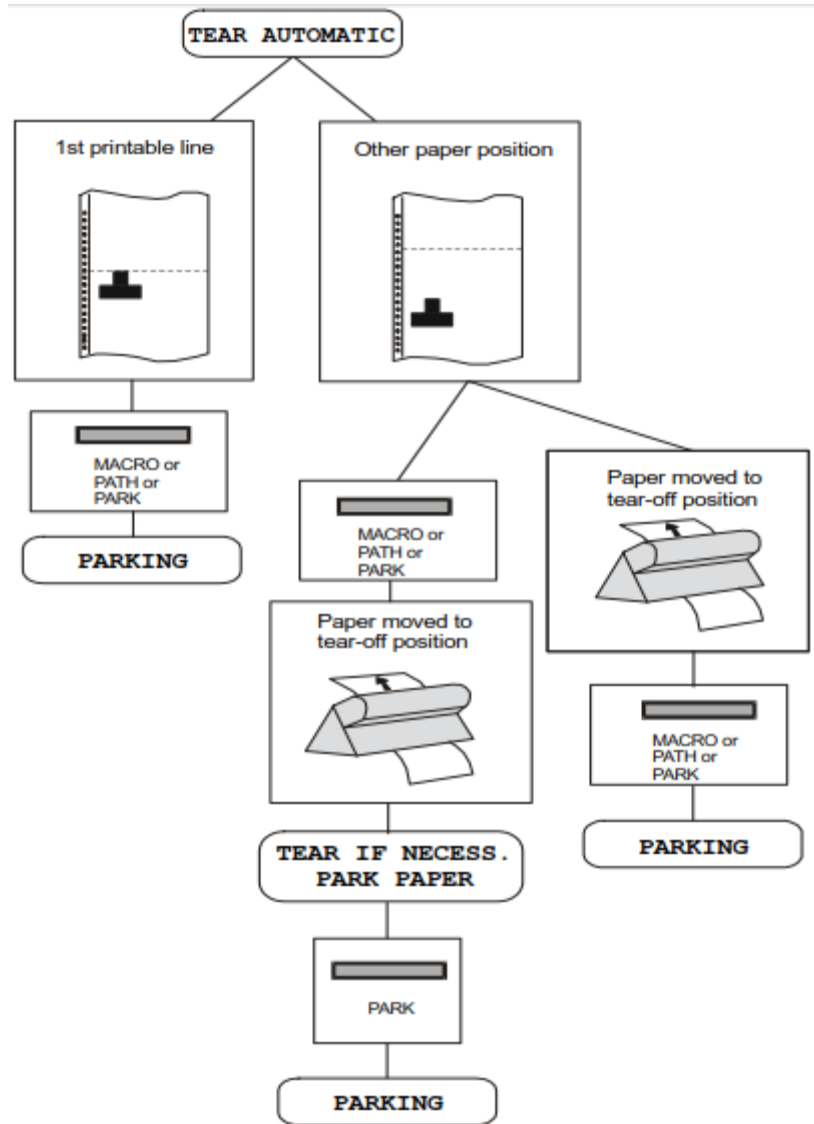

If LABEL is selected:

- When the paper is positioned at the first printable line and the paper path is changed (changing the Macro or pressing the PATH key), or the PARK key is pressed the printer automatically ejects the paper towards the rear of the printer.
- If at least one line has been printed, or the paper has been fed forward at least 1 line and the paper path is changed (changing the Macro or pressing the PATH key) or the PARK key is pressed, the display shows TEAR IF NECESS./EJECT PAPER. If the paper to be ejected is longer than 18" tear it off and press the PARK key again to perform the paper ejection.

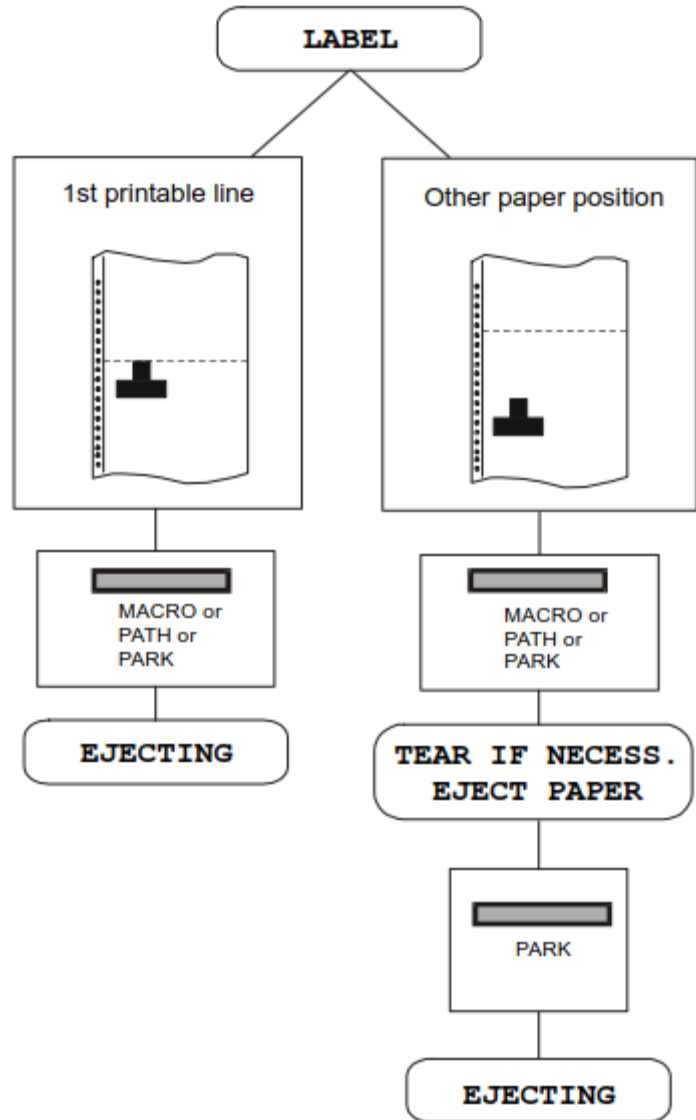

If at power on the paper is already loaded in a paper path that is different to the paper path used by the macro which is valid at power-on, independently from the setting of the TEAR function, the display shows TEAR IF NECESS./EJECT PAPER. If the paper to be ejected is longer than 18" tear it off and press the PARK key again to perform the paper ejection.

In all the above cases the parking procedure may be interrupted pressing the ALTERNATE key. The display shows OPER. INTERRUPTED.

If in any of the above cases you do not tear off the paper and the printer is not able to park it, because it is too long, the display shows TEAR OFF PAPER/PARK PAPER. Tear off the paper and press again the PARK key.

During the parking procedure the display shows PARKING. If the printer is ejecting the paper (see LABEL selection) the display shows EJECTING.

Paper Paths

Paper Handling

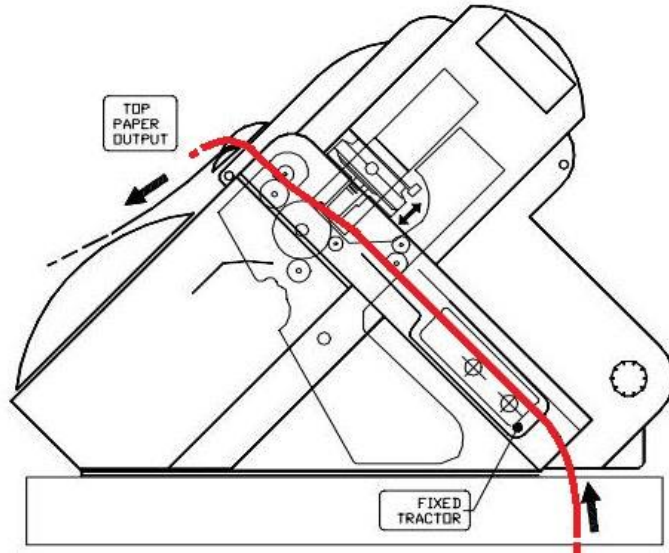

Front 1 Push Path

Base Configuration

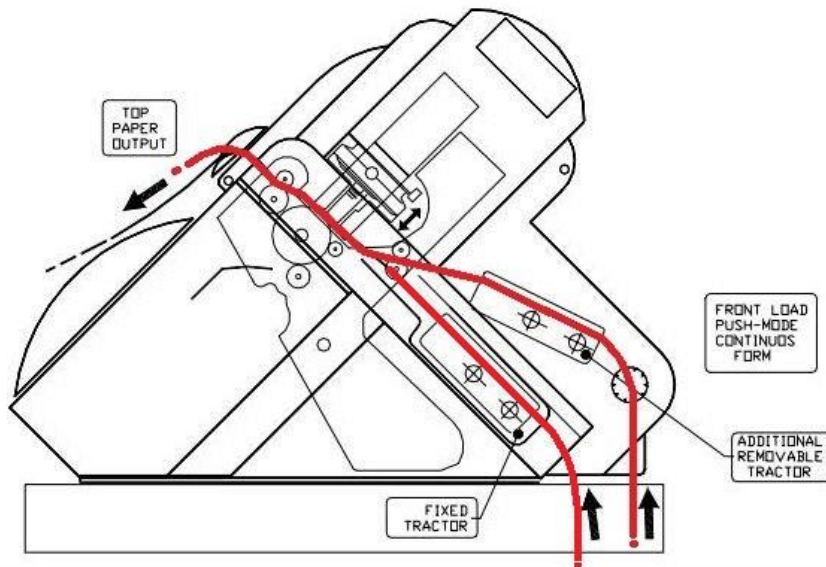

Front 2 Push Path

With Installed Option

Paper Specifications

It is important to use the correct paper for obtaining the best performance. See the information table below:

Fanfold Paper

Paper Criteria	Characteristics	Continuous Form
		Front Push, Rear Push
Dimensions	Width	76,2 to 431.8 mm - 3 to 17 in.
	Length	76,2 to 609.6 mm - 3 to 24 in.
Single Part	Weight	55 to 150 gm ² - 15 to 40 lb
	Thickness	0.08 to max. 0.635 mm - 0.003 to 0.025 in.
Multiple Parts	Maximum Parts (Original + Copies)	1+ 7 Chemical 1+5 Carbon Paper
	Overall Thickness	0.08 to max. 0.635 mm - 0.003 to 0.025 in.
	Weight of top part	55 to 150 gm ² - 15 to 40 lb
	Attached sheet individual weight	45 to 75 gm ² - 12 to 20 lb
	Carbon paper individual weight	14 to 35 gm ² - 4 to 9 lb

Fanfold Paper Loading

Loading Paper Using the Front1 Push Tractor

- To select the Front1 push tractor paper path, press the PATH key. The display shows:

LOAD FRONT1

- If you have been using a different path, the display shows:

PATH CHANGING

- If you have been using fanfold paper in the Front2 push tractor paper path (if the Front2 push tractor option is installed), the printer automatically starts the parking procedure. The display shows alternately:

TEAR IF NECESS.

and

PARK PAPER

- Tear off the fanfold loaded with the Front2 push tractor (if it is longer than 18 inches) and press the PARK key. The display shows:

PARKING

followed by

LOAD FRONT1

1. Open the Push tractors cover turning it upwards and lay it on the top of the printer

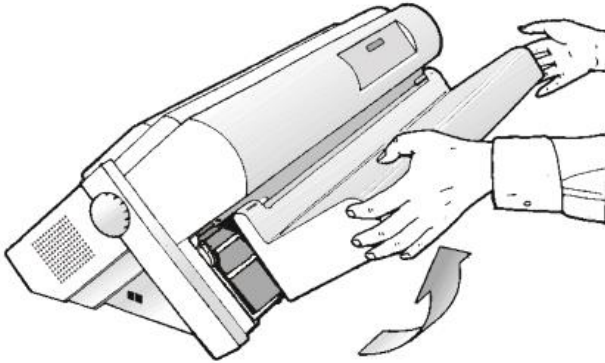

2. Unlock the sprockets of the Front1 tractor moving the sprocket levers down. Slide the left sprocket to the first printing column.

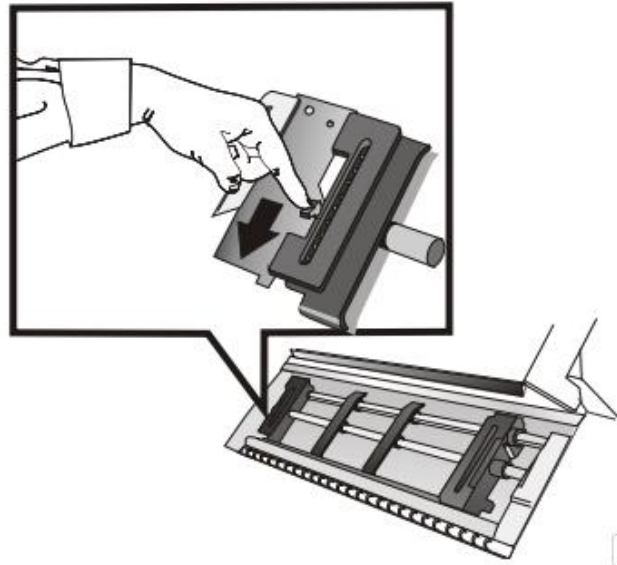

Note: in some version the sprocket levers work in opposite way instead of the same way as the indicated in the figures

3. Space the paper guides along the tractor bar. Open the left and right sprocket covers.

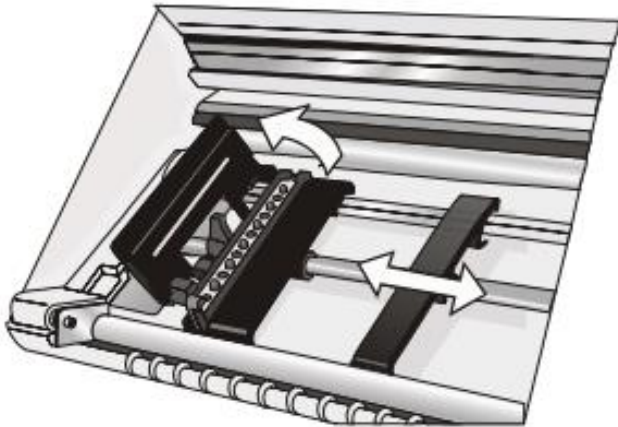

4. Hold the fanfold paper in front of the sprockets and insert the paper perforation on the left sprocket pins and close the left sprocket cover

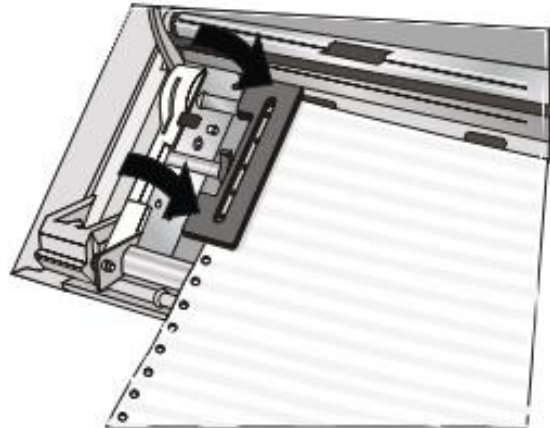

5. Insert the paper on the right sprocket pins and close the right sprocket cover
6. If you are using the 6 pin Front1 Push tractor option, make sure the paper goes under the paper sensor, and close the right sprocket cover.

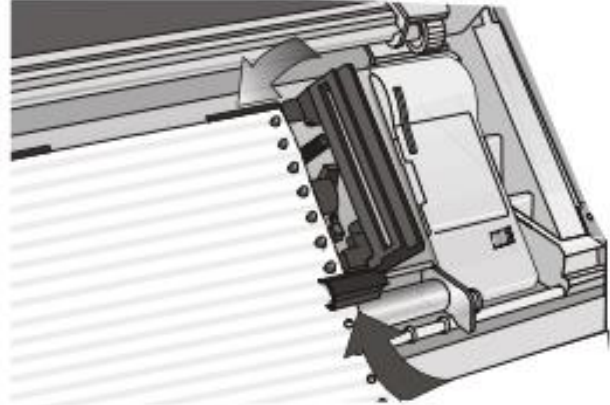
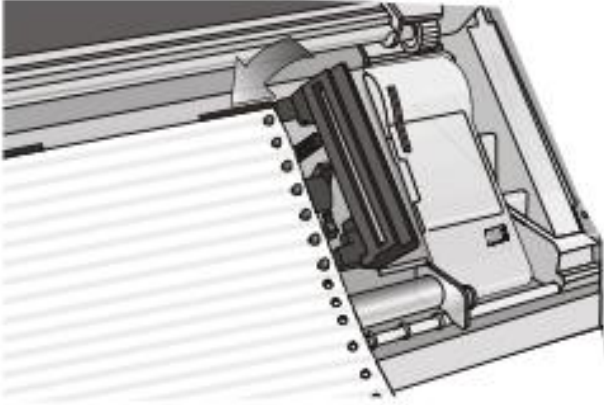

7. Match the left sprocket for the first printing position, i.e. the left paper margin must match the ninth mark on the printer cabinet
8. Adjust the right sprocket gently to remove slack from the paper

Note: Aligning the left-hand edge of the paper past the 22nd spacer on the printer cabinet will cause the paper to be misaligned with the Paper Load Sensor resulting in a 'LOAD FORM' error.

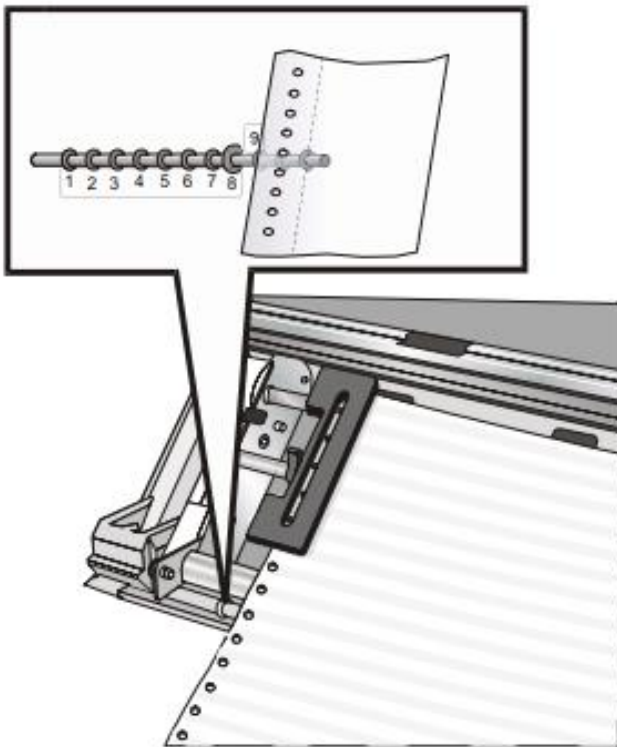

Make sure the paper is not taut

9. Lock the left and right sprockets moving the sprocket levers up

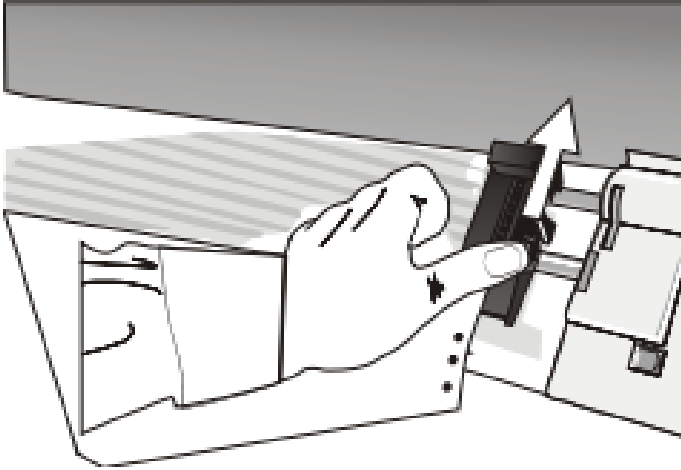

10. Close the Push tractors cover. Press the LOAD/FF key to load the paper into the printer. The paper must be loaded as shown in figure.

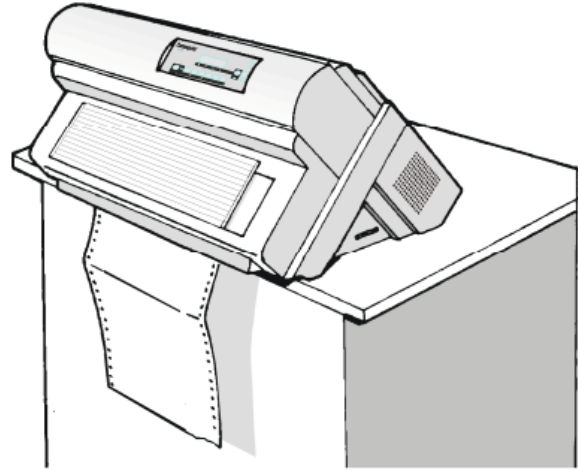

Printing a Configuration Sheet

It is recommend that you now print your printer configuration defaults. Save this printout for future reference. You can create a printout of the printer configuration by following these steps:

1. Press the ON LINE key to take the printer OFF LINE.
2. Press the PROGRAM key. Is displayed
3. Press the → key The PROGRAM SETUP PRINTOUT is printed
4. Press the ↓ key until Is displayed
5. Press the → key The USAGE STATISTICS DATA PRINTOUT is printed
6. Press the ↓ key until Is displayed
7. Press the → key to display
8. Press the ↓ key Is displayed
9. Press the → key The CONFIGURATION SETUP PRINTOUT is printed
10. Press the PROGRAM key
11. Press the TEAR key and tear off the printout at the perforation

Printer Maintenance and Troubleshooting

Cleaning the Printer

**DANGER**

<2-22> Carefully follow all cleaning instructions, using only the materials and solutions recommended.

Before you clean the Printer, make sure the printer has been turned off for at least 15 minutes before starting any cleaning operations

Periodic cleaning will help keep your printer in top condition so that it will always provide optimal performance.

Cleaning inside the printer

Every few months, use a soft brush and a vacuum cleaner to remove dust, ribbon lint, and pieces of paper such as chad. Remove the ribbon cartridge to prevent the ribbon from going into the vacuum cleaner. Vacuum any dust from around the print head and in the printer cavity.

Attention: Do not allow any staples, paper clips, or small metal pieces to fall inside the printer.

Cleaning the outside covers

Clean the outside of the printer with a damp cloth and mild soap. Do not use any spray-type or chemical cleaners anywhere on your printer. Do not put any liquids or spray near the air vents. For stubborn ink stains on the cover, use a commercial mechanic's hand cleaner.

Replacing the Ribbon Cartridge

1. Make sure that the printer is turned off for at least 15 minutes.



CAUTION:

The printhead may get hot during operation. Be careful when removing or replacing the ribbon..

2. Open the top printer cover.
3. Slide the ribbon guide out of the print head. If the Ribbon Shifter kit is installed on the printer, free the shifter holder pushing the tab towards the rear and pulling the shifter holder up.

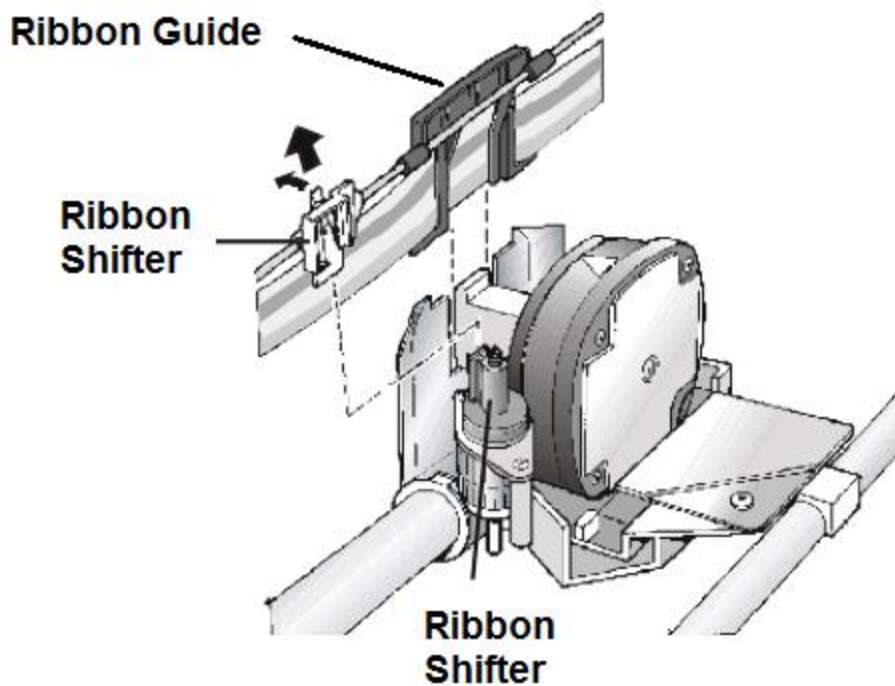

3. Remove the cartridge by lifting it up.

used ribbon

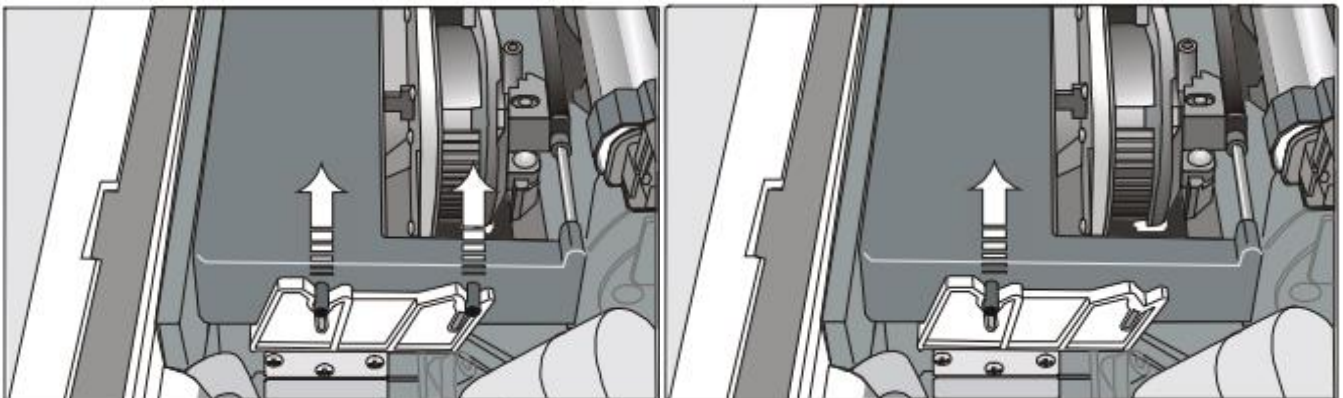

Black cartridge when the ribbon shifter option is not installed

Black "Long Life" cartridge when the ribbon shifter option is installed

Now, you are ready to insert the new ribbon cartridge. See before "[Ribbon Cartridge Installation](#)".

Printing the Self Test

If you need to know any printer setting, and to check if the printer is working well, print the self- test.

Proceed as follows:

1. Keep the ON LINE key pressed while powering on the printer until the display shows RELEASE KEYS.
2. When you release the key, after initializing the printer starts the self-test printout.

It prints:

- The printer model
- The current firmware release with Version and FW Identifier
- The serial number which can be applied as USB ID
- The MAC ADDRESS of the LAN card

Plus a continuous loop of characters in different pitches.

3. To stop the self-test printing, press the ON LINE key again. The printer is offline.

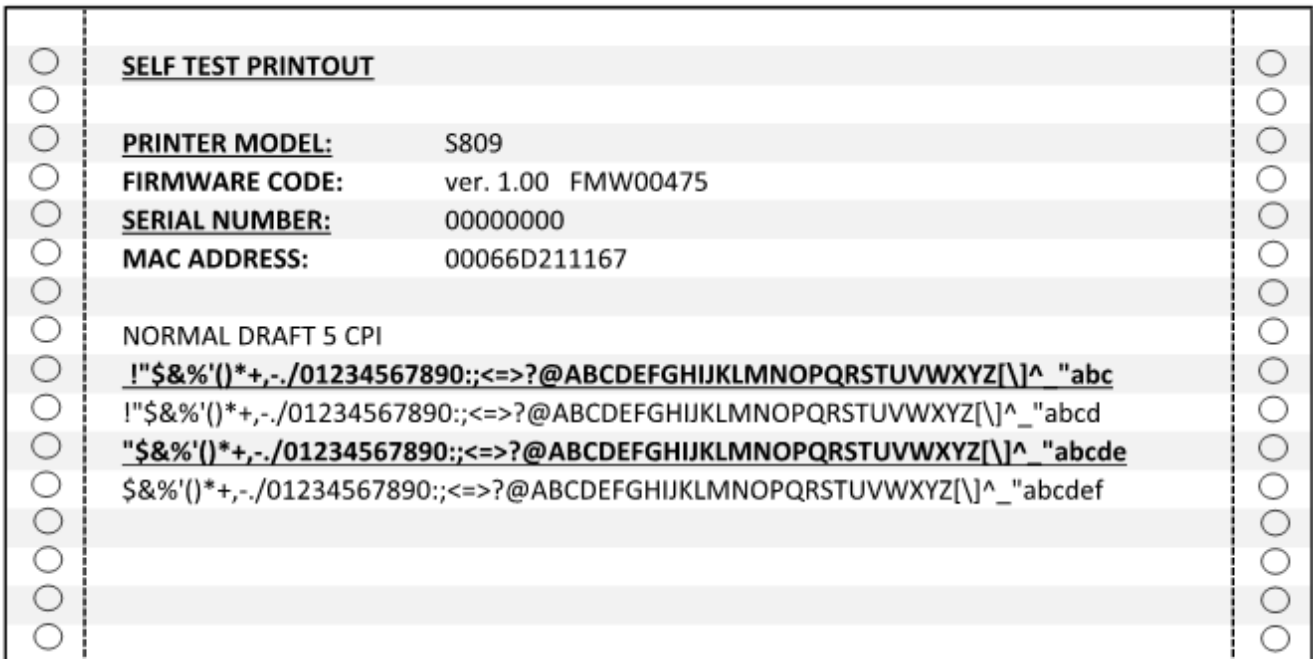

Error Handling

When an error condition occurs:

- the printer is disabled;
- the first message on the display indicates the error, while the second message gives more details concerning the error conditions.

Press always the ON LINE key to reset the error condition

Error Message Description

Messages	Indication	Solution
A.G.A NOT OPER ADJUST THE GAP	The automatic gap adjustment (A.G.A) is not enabled.	<p>Press the ON LINE key to reset the error condition. Adjust the print head gap to a fixed distance. Select the print head fixed gap adjustment function in the <i>Program Menu</i>.</p> <ul style="list-style-type: none"> • Press the PROGRAM key when the printer is disabled (READY indicator unlit) to enter the <i>Program Setup</i>. • Press the ↓ key until the USER MACRO function is displayed. Press the → key until the desired macro is displayed (MACRO#x). <p>Press the → key to enter the macro parameters. Press the ↓ key until the FIXED GAP parameter is displayed. Press the → or ← keys to select the fixed gap adjustment values. From FIXED GAP 1 (simple fanfold paper) to FIXED GAP 4 (multipart fanfold paper).</p>
BUFFER OVERFLOW CHARACTER LOST	A buffer overflow condition occurred (for the serial interface).	<p>Turn the printer off and on again, or press the PROGRAM and ON LINE key successively to clear the buffer.</p> <ul style="list-style-type: none"> • Press ON LINE to clear the error. • Increase the buffer size. • Check the handshaking protocol in the CONFIGURATION SET UP against the host protocol. • Restart the print job.
DATA SET OFF	A remote connection serial interface error condition was detected. The Data Set Ready or Data Carrier Detect signal was not sensed.	<p>Check for the correct serial cable for the remote Connection.</p> <ul style="list-style-type: none"> • Press the ON LINE key to reset the error condition.
FRAMING ERROR CHARACTER LOST	<p>An error on the serial transmission occurs.</p> <p>The printer recognized a wrong bit, printer recognized a wrong bit.</p>	<p>Turn the printer off and on again, or press the PROGRAM and ON LINE key successively to clear the buffer.</p> <ul style="list-style-type: none"> • Press ON LINE to clear the error. • Increase the buffer size.

Messages	Indication	Solution
INTERLOCK ERROR CHECK INSERTION	The rear plug cover is not installed on the printer.	Install the rear plug cover on the printer.
JAM FRONT1 PATH CHECK PAPER	A paper jam error condition occurred in the Front1 paper path.	Check the paper path and remove the jammed paper. Press the ON LINE key to reset the error condition.
JAM FRONT2 PATH CHECK PAPER	A paper jam error condition occurred in the Front2 paper path.	Check the paper path and remove the jammed paper. Press the ON LINE key to reset the error condition.
NO PATH AVAILABLE	An electromechanical failure occurs in the paper paths.	Call Service.
NVM CHANGE REMOVE PAPER	If this error is displayed during the printer power on, an NVM error condition occurs.	Turn the printer off and then on again. If the problem is not solved call Service.
OVERRUN ERROR CHARACTER LOST	An error on the serial transmission occurs. The printer recognized a wrong bit. printer recognized a wrong bit.	Turn the printer off and on again, or press the PROGRAM and ON LINE key successively to clear the buffer. <ul style="list-style-type: none"> • Press ON LINE to clear the error. • Increase the buffer size.
PAPER JAM CHECK ALL PATHS	A paper jam error condition occurs in the paper path.	Check all the paper paths and remove the jammed paper. Press the ON LINE key to reset the error condition.
PARITY ERROR CHARACTER LOST	An error on the serial transmission occurs. The printer recognized a wrong parity bit.	Turn the printer off and on again, or press the PROGRAM and ON LINE key successively to clear the buffer. <ul style="list-style-type: none"> • Press ON LINE to clear the error.
PRINT INTEGRITY	Anomalous print out because of a possible print carriage blocking.	<ul style="list-style-type: none"> • Do not move the platen knob. Press the ON LINE key to reset the error condition.
RIBBON BLOCKED CHECK RIBBON	The ribbon of the cartridge is blocked.	Check that the ribbon is correctly inserted. Turn the tension knob to make sure that the ribbon is not jammed. Press the ON LINE key to reset the error condition.
UNKNOWN TRACTOR	A tractor type that is not recognized has been mounted on the printer.	Check that the installed tractor is compatible with the printer.
ENG FLT ERR XYZ	A not-recoverable is detected during initialization phase <ul style="list-style-type: none"> • carriage movement • ribbon movement • paper sensor 	Check for objects inside of the printer blocking carriage, ribbon or paper movement. Turn the printer off and on again, If the problem persists call for service.

Problems List Index

1. **"Forms problems"** on page 104
 - "Problem: Forms buckle, twist, jam, or tractor holes tear" on page 104
 - "Problem: Forms do not feed past printhead" on page 104
 - "Problem: Forms do not stack correctly" on page 104
 - "Problem: Characters are off registration" on page 105
2. **"Print quality and ribbon problems"** on page 105
 - "Problem: Unreadable characters" on page 105
 - "Problem: Missing dots or irregular characters" on page 105
 - "Problem: Ribbon smudging forms" on page 105
 - "Problem: Printing is too light or partial characters print" on page 106
 - "Problem: Ribbon snagging, tearing, or not moving" on page 106
3. **"Configuration problems"** on page 106
 - "Problem: Printer doesn't print or prints wrong characters" on page 106
4. **"Miscellaneous problems"** on page 106
 - "Problem: Printer has no power" on page 106
 - "Problem: Throughput of printer at half speed" on page 106

Forms problems

Causes are listed for each problem in order of priority.	
Problem: Forms buckle, twist, jam, or tractor holes tear	
1. The right tractor is adjusted incorrectly	Solution: Move the right tractor to obtain proper forms tension. The tractor pins should be in the center of the tractor holes.
2. The printer is not at the edge of the table.	Solution: Move the printer to the front edge of the table if having problems with front forms path or move the printer to the rear edge of the table if having problems with the rear forms path.
3. The forms supply is not below the level of the printer.	Solution: Move the forms supply to the floor or on a shelf below the level of the printer.
4. The forms supply is not aligned with the printer.	Solution: Reposition the forms supply so that the forms feed evenly.
5. The forms are catching on the carton edge.	Solution: Remove the uneven carton edges, or remove the forms from the carton.
Note: As the forms reach the bottom of the box, this problem can occur more often.	
6. The ribbon is twisted or folded.	Solution: Check the ribbon for folds or twists.
7. The forms contain excessive moisture.	Solution: Store the forms in a cool, dry place before using them, or store the forms in the printer area for 24 hours.
8. The forms are defective or do not meet specifications	Solution: Try unloading the forms and then reloading forms. Forms should meet the requirements specified in "Paper Specifications" on page 95.
Problem: Forms do not feed past printhead	
1. The Automatic Gap Adjustment (AGA) setting for the paper source you are using needs to be changed	Solution: See "Adjusting the Distance of the Print Head" on page 74
2. The ribbon is twisting or folding.	Solution: Replace the ribbon.
3. You are using thick multiple-part forms	Solution: See the procedure for setting perforation safety to Yes through the operator panel. See "Paper Perforation" on page 74.

Problem: Forms do not stack correctly	
1. The forms do not stack correctly on the table behind the printer	Solution: Use the recommended table size (see "Choosing a Suitable Location" on page 9).
Note: Up to 101.6 mm (4 in.) of forms may stack on the table behind the printer without decreasing the ability of the forms to stack correctly.	
2. The forms do not stack correctly in the output rack on the table.	Solution: Check for obstructions to the forms path (cables, cords, or other items). If you find an obstruction, remove or relocate it.
3. The forms do not meet specifications.	Solution: The forms may be outside nominal specifications. See "Paper Specifications" on page 95.
4. The forms contain excessive moisture.	Solution: Store the forms in a cool, dry place before using them or leave in the printer for 24 hours.
Note: Forms stack best when the forms are 203.2 to 304.8 mm (8 to 12 in.) long. If the forms length is outside this range, operator assistance may be needed	
5. Forms are too dry.	Solution: Condition the forms for 24 hours or more at the manufacturer recommended temperature and humidity settings.
Problem: Characters are off registration	
1. The first print position is adjusted incorrectly.	Solution: Check your settings for the "Left Margin" on page 71, "Horizontal Character Tuning" on page 75, and "Vertical Character Tuning" on page 75.

Print quality and ribbon problems

Problem: Unreadable characters	
1. The ribbon is dry or worn.	Solution: Check the ribbon and replace it if it is dry or worn.
2. The Automatic Gap Adjustment (AGA) setting for the paper source you are using needs to be decreased. Paper must be loaded for this adjustment to be effective.	Solution: See "Adjusting the Distance of the Print Head" on page 74.
3. Poor-quality multiple-part forms.	Solution: Try new forms or select another print quality. See "Quality Print Mode Selection" on page 69.
4. Forms thickness exceeds forms specifications.	Solution: See "Paper Specifications" on page 95.
Problem: Missing dots or irregular characters	
1. The ribbon is worn.	Solution: Check the ribbon for wear; replace it if necessary.
2. The ribbon is twisted or folded.	Solution: Straighten the ribbon.
3. The Automatic Gap Adjustment (AGA) setting for the paper source you are using needs to be changed. Paper must be loaded for this adjustment to be effective.	Solution: See "Adjusting the Distance of the Print Head" on page 74.
Problem: Ribbon smudging forms	
 <p>CAUTION: <2-25> High temperature; switch off the printer and allow at least 20 minutes for parts in this area to cool before handling.</p>	
1. The ribbon is twisted or folded.	Solution: Try moving the printhead back and forth while turning the ribbon advance knob. If the ribbon advance knob does not turn, replace the ribbon.
2. The Automatic Gap Adjustment (AGA) setting for the paper source you are using needs to be increased. Paper must be loaded for this adjustment to be effective.	Solution: See "Adjusting the Distance of the Print Head" on page 74.

3. The ribbon cartridge is defective	Solution: Replace the ribbon cartridge.
4. A new ribbon is over-inked.	Solution: Replace the ribbon.
Problem: Printing is too light or partial characters print	
1. The Automatic Gap Adjustment (AGA) setting for the paper source you are using needs to be changed. Paper must be loaded for this adjustment to be effective	Solution: See "Adjusting the Distance of the Print Head" on page 74.
2. The ribbon guide is seated incorrectly or the cartridge is not snapped into place.	Solution: Remove the ribbon and reinstall it.
Problem: Ribbon snagging, tearing, or not moving	
1. The ribbon is worn	Solution: Replace the ribbon cartridge.
2. The ribbon cartridge is not properly installed	Solution: Remove and then reinstall the same ribbon.

Configuration problems

Problem: Printer doesn't print or prints wrong characters	
1. Nothing is printed or the wrong characters print.	Solution: - Ensure the printer cable is attached to the host. - Check the printer configuration settings.

Miscellaneous problems

Problem: Printer has no power	
1. The power cord is not connected.	Solution: Ensure the power cord is plug into the back of the printer and also into the wall outlet.
Problem: Throughput of printer at half speed	
1. The Quiet Print function is set to ON.	Solution: Set Quiet Print to OFF. See "Quiet Printing" on page 74.

Clearing Forms Jams

Use the following procedure to clear forms jams from the printer

1. Open the top cover
2. Tear off the forms at perforations before it enters the printer and after it exits the printer.
3. Open the tractor doors and remove forms from the tractors.
4. Try to move the printhead off of the form and to the far right. Do not force it.
5. Remove jammed forms by pulling in the direction of printing.
6. If the jam cannot be removed, lightly pull the form in the opposite direction.
7. If the jam still cannot be removed, remove the paper bail assembly:
 - a. Remove the ribbon cartridge.
 - b. Grip the bail assembly and rotate it toward the front of the printer until the pivot posts on the sides disengage from the printer frame.
 - c. Lift the bail assembly out of the printer and set it aside.
 - d. Remove jammed forms by pulling in the direction of printing
8. If you removed the paper bail assembly in the previous step, reinstall it, as follows:
 - a. Grip the bail assembly as shown in the following illustration.

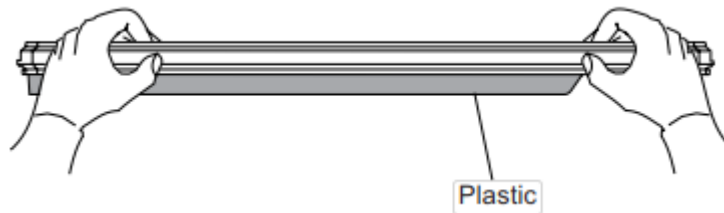

Important!

To avoid damaging the plastic, ensure the plastic points down.

- b. Insert the left and right paper bail end cap pivots into the side frames as indicated in the figure below

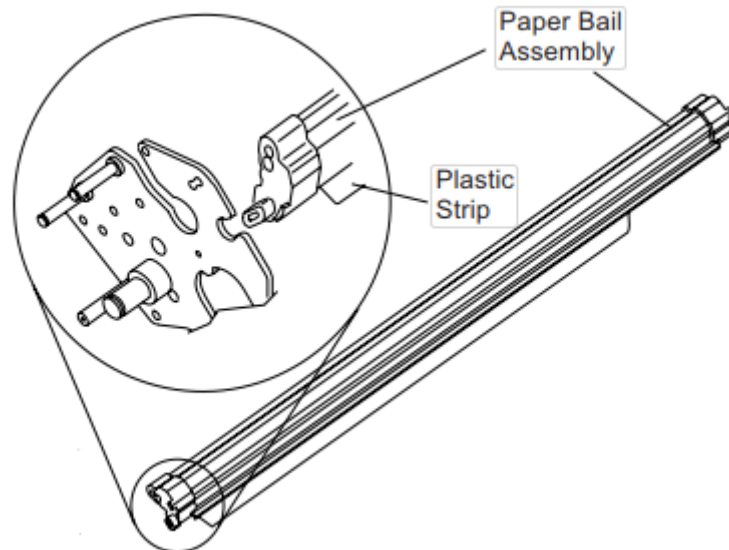

- c. Rotate the paper bail assembly toward the back of the printer, closing it as far as it will go.
 - d. Reinstall the ribbon cartridge
9. Reload the forms.

Options

The double byte Controller Board (only for 809 DBCS)

The S809 printer's interface available configurations are:

- Controller board with serial, parallel and USB interfaces
- Controller board with LAN and parallel interfaces.

The original configuration may be modified by ordering the controller board with the desired interfaces and replacing the existing board with it.

Installing the Controller Board

Follow the reported instruction in case of Controller Board replacement.

Handling the Controller Board

Attention: Do not remove the Controller Board from the protective package until instructed to do so. Static electricity, though harmless to you, can damage sensitive Controller Board components. Use the information in this section to avoid damaging a Controller Board.

- Limit your movement. Your movement can create static electricity that, when released to the Controller Board, can damage the electronic components on the Controller Board. Sliding your foot across carpeting is an example of how you create unwanted static electricity.
- Handle the Controller Board only by the edges and prevent others from making direct contact with it.
- Before removing the Controller Board from the protective package, ground the package to exposed metal at the back of the printer. This will release any static charge that may have developed on the package or on your body. Hold the package against the metal for at least two seconds.
- When you are instructed, remove the Controller Board and install it directly into the Controller Board slot without setting it down. If you have removed the Controller Board from the protective package and cannot immediately insert it in the printer, place the protective package on a flat surface, and set the Controller Board on top of the protective package.

Replacing the Controller Board

Attention: Ensure that the printer is powered off before installing or removing the Controller Board.

If the Controller Board is installed while the printer is powered on, the controller will not synchronize with the printer mechanism board.

Unpredictable printer behavior will result.

Perform the following steps to replace the Controller Board:

1. Ensure that the printer is powered off. Installing the Controller Board with the printer power on will result in unpredictable printer behavior.
2. Use the screwdriver that came in the Controller Board box to remove the existing Controller Board and pull out the card.

3. Use the information under "Handling the Controller Board" on the preceding page as you remove the Controller Board from its shipping box and from the protective package.
4. Align the left and right sides of the Controller Board with the guides in the printer and slide it into the slot.

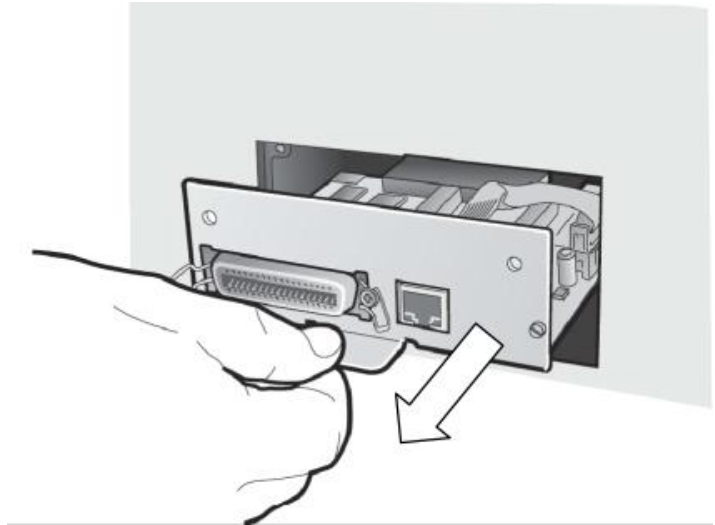

2. Use the information under "Handling the Controller Board" on the preceding page as you remove the Controller Board from its shipping box and from the protective package.
3. Align the left and right sides of the Controller Board with the guides in the printer and slide it into the slot.

4. Gently push the Controller Board into the printer until it is seated in the connector inside the printer.
The Controller Board is correctly seated in the printer when the Controller Board metal plate is aligned with the back profile of the slot.

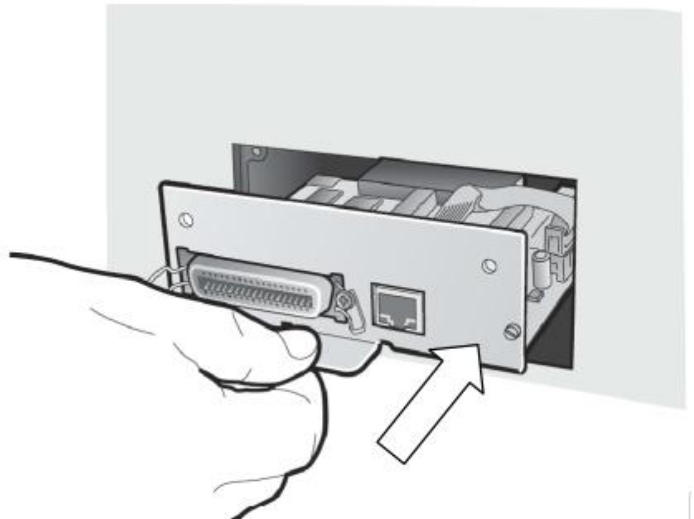

6. Attach the Controller Board with the two screws using the screwdriver that came in the Controller Board box.

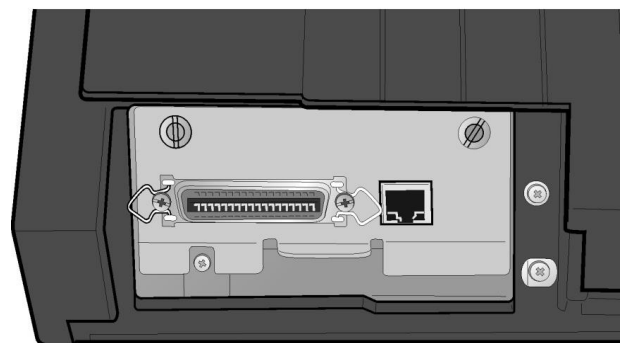

The Front2 Push Tractor

The 6 pin Front2 Push Tractor is available for the S809 printer.

An optional second front push tractor can be installed on the printer model. This tractor allows the handling of a second fanfold paper.

Installing the Front2 Push Tractor

This second push tractor can be installed in front position on the Front1 Push tractor.

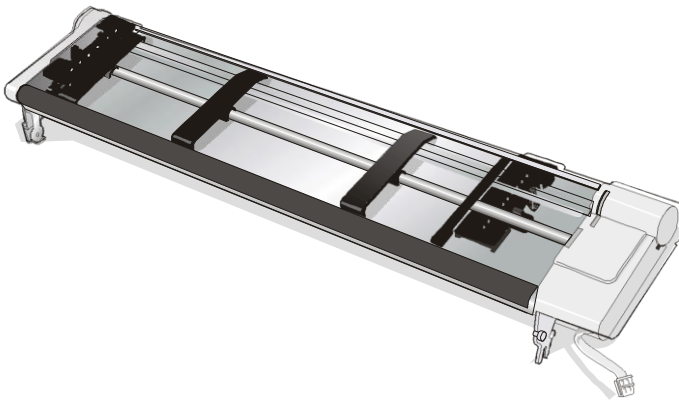

6 pin Front2 Push Tractor option

1. Align the hooks on both sides of the Front2 push tractor with the pins on the Front1 push tractor

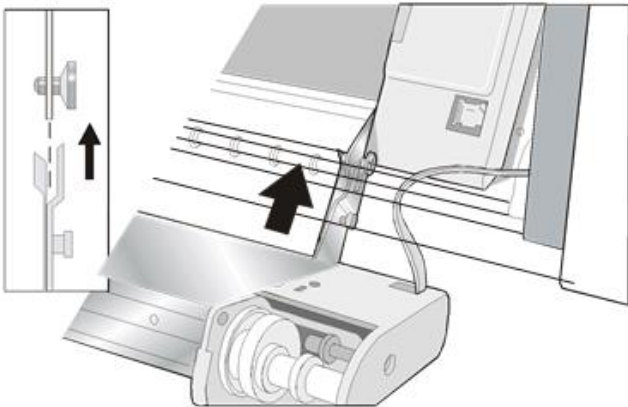

2. Push the Front2 tractor until it is fully engaged

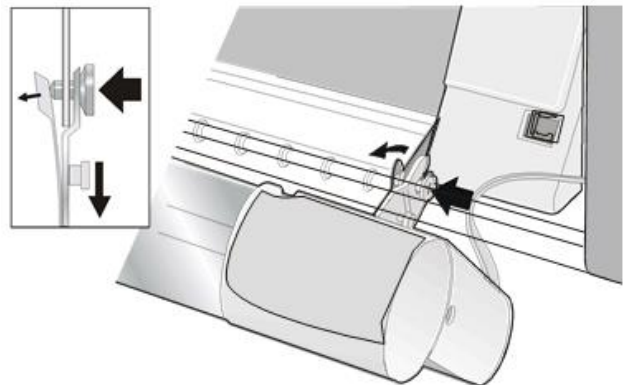

3. Insert the connector cable in the electrical connector located in the lower push tractor

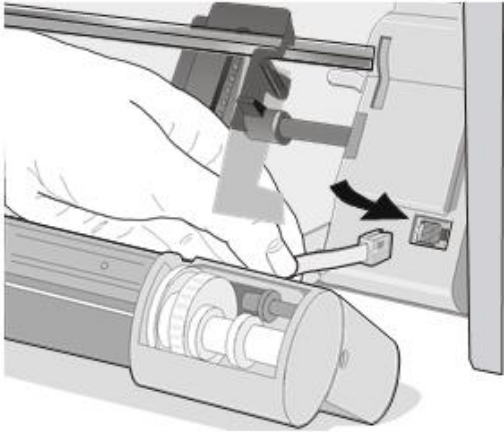

4. Rotate the Front2 push tractor onto the Front1 push tractor.

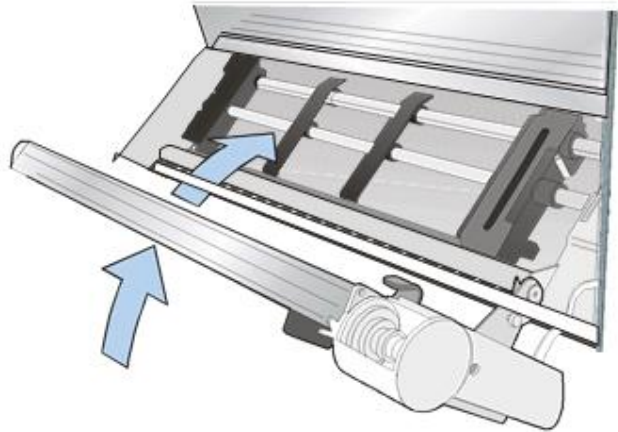

Removing the Front2 Push Tractor

If you need to remove the upper push tractor, turn the printer off. Disconnect the connector cable and press on the push buttons to disengage the Front2 push tractor

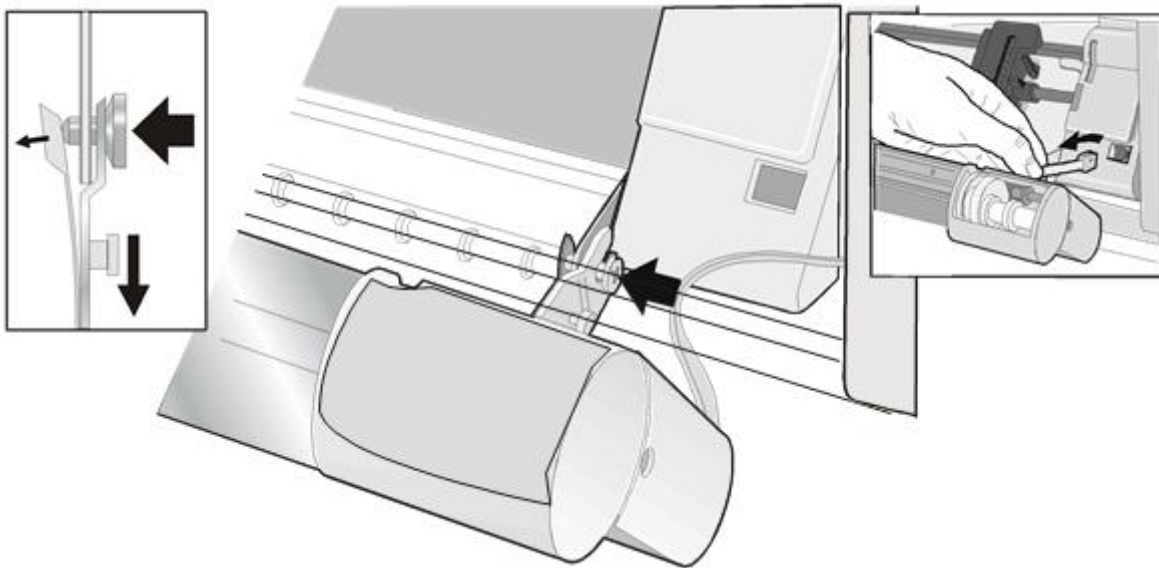

Loading Paper Using the Front2 Push Tractor (option)

- To select the Front2 push tractor paper path press the PATH key until the display shows:

LOAD FRONT2

- If you have been using a different path, the display shows:

PATH CHANGING

- If you have been using fanfold paper in the Front1 push tractor paper path, the printer automatically starts the parking procedure. The display shows alternately.

TEAR IF NECESS.

and

PARK PAPER

- Tear off the fanfold loaded with the Front1 push tractor (if it is longer than 18 inches) and press the PARK key. The display shows:

PARKING

followed by

LOAD FRONT2

- Open the Push tractors cover turning it upwards and lay it on the top of the printer

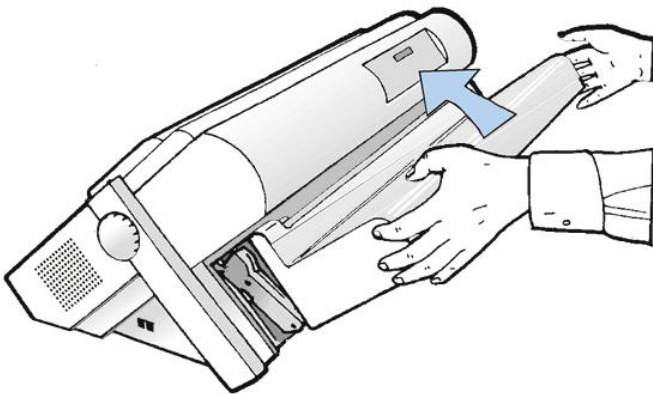

- Unlock the Front2 push tractor sprockets moving the sprocket levers up

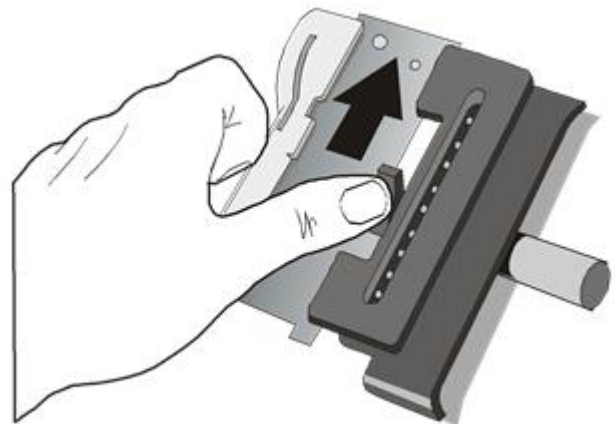

Note: in some version the sprocket levers work in opposite way instead of the same way as the indicated in the figures

4. Space the paper guides along the tractor bar. Open the sprocket covers of the left and right sprocket

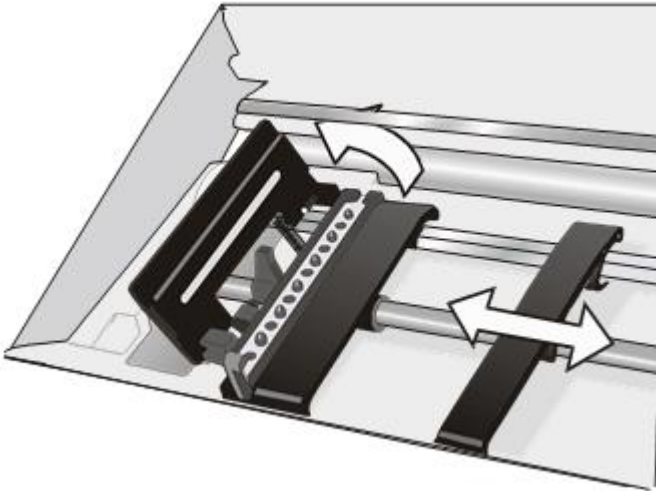

5. Hold the fanfold paper in front of the sprockets and insert the paper perforation on the left sprocket pins and close the sprocket cover. Insert the paper on the right sprocket pins and close the sprocket cover.

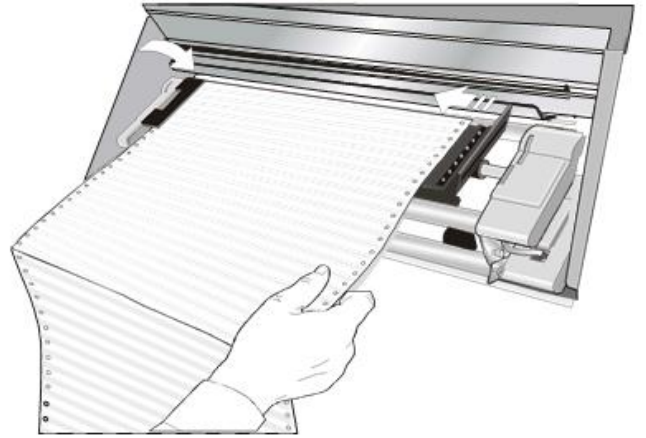

6. If you are using the 6 pin Front2 push tractor option, make sure the paper goes under the paper sensor and close the sprocket cover.

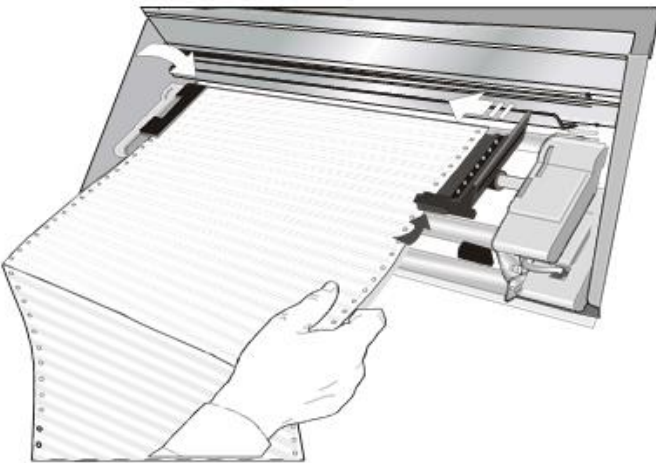

7. Position the left sprocket for printing, matching the left paper margin with the ninth notch on the printer cabinet and lock it in place

Note: Aligning the left-hand edge of the paper past the 22nd spacer on the printer cabinet will cause the paper to be misaligned with the Paper Load Sensor resulting in a LoadForms' error.

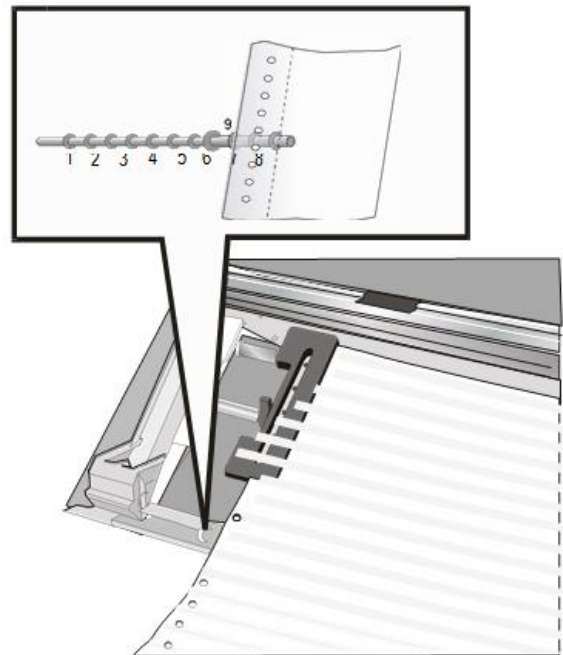

- Adjust gently the right sprocket to remove slack from the paper. Lock the Front2 tractor sprockets moving the sprocket levers down.

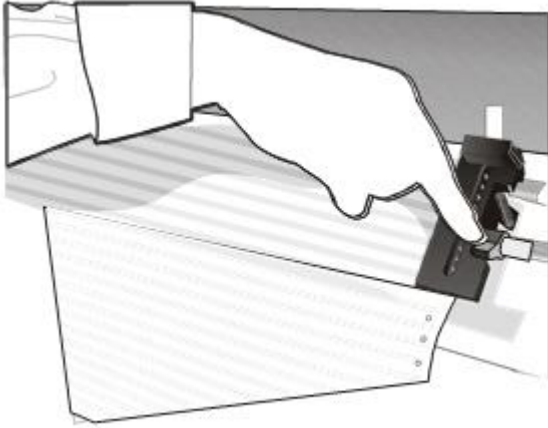

- Close the Push tractors cover. Press the LOAD/FF key to load the paper into the printer.

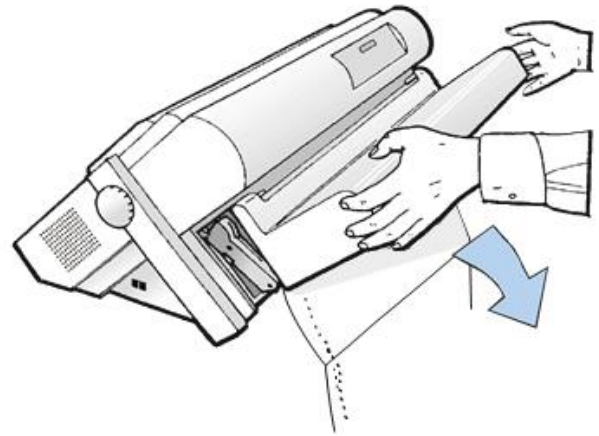

Loading Paper Using the Front1 Push Tractor when the Front2 Push Tractor (Option) is Installed

When the Front2 push tractor option is installed and you need to load paper on the Front1 push tractor follow this paper loading procedure:

- Open the Push tractors cover turning it upwards and lay it on the top of the printer. Rotate the Front2 push tractor option outside the printer.
- Insert the fanfold paper between the Front1 and Front2 push tractor, then proceed to load the paper as described in the section "Loading Paper Using the Front1 Push Tractor".

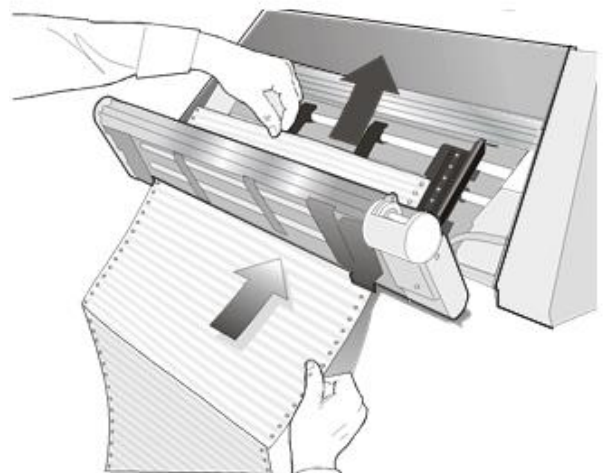
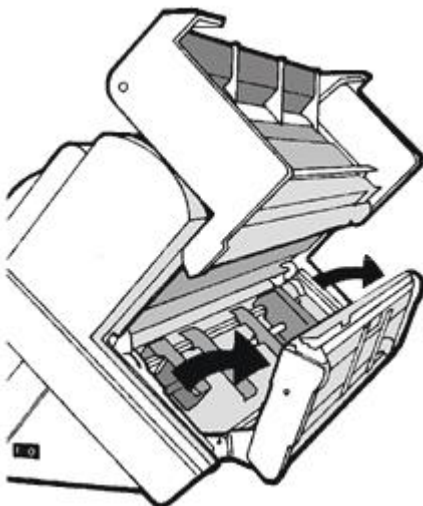

3. When the fanfold paper has been loaded on the Front1 push tractor, reposition the Front2 push tractor in its initial position before closing the Push tractors cover

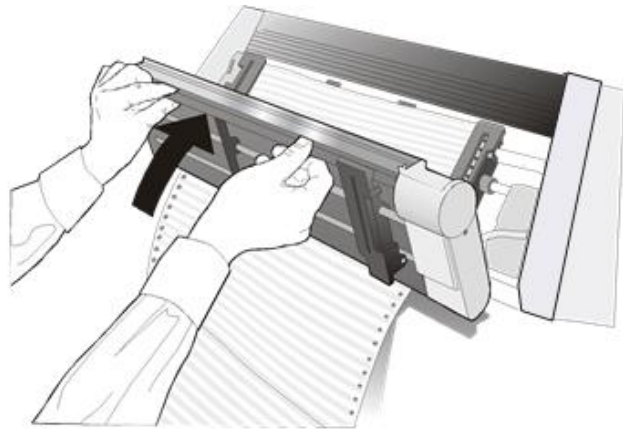

The Printer Pedestal

For better paper handling, use the available Closed Floor printer pedestal option. The pedestal is shipped as a kit is a safety carton box. The instructions how to install it are inside the box.

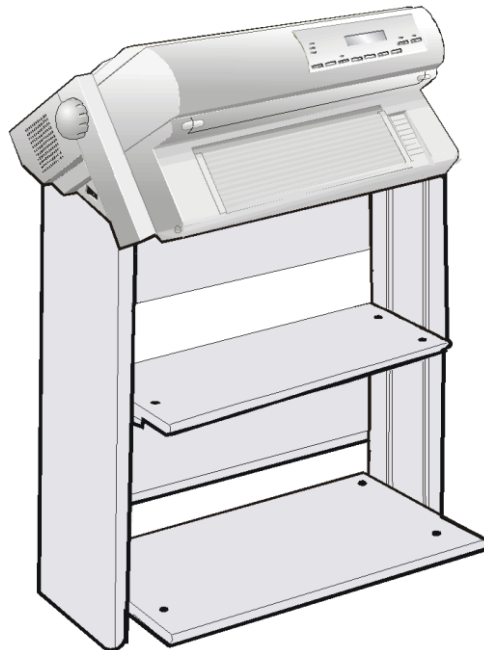

Printer Specifications

Printing Characteristics

Print Head						
Matrix	24 pins - 0.25 mm					
Print Speed (cps) in SBCS						
CPI	High Speed Draft	Normal Draft	Best Draft	NLQ	LQ	
10	900	800	400	267	133	
12	-	960	480	320	166	
15 micro	-	1200	600	400	200	
Throughput Mode (ECMA132) in SBCS						
Pages per Hour		Print Mode		Speed		
		Draft-High Speed Draft		610		
		Spreadsheet 10CPI		435		
Lines per minute @10 cpi		40 characters/line		450		
		80 characters/line		330		
		136 characters/line		250		
Print Matrix (horizontal x vertical) in SBCS						
CPI	Draft			Quality		
Print Mode	High Speed	Normal	Best Draft	LQ	NLQ	
10	9 x 12	12 x 12	12 x 24	36 x 24	36 x 12	
12	-	10 x 12	10 x 24	30 x 24	30 x 12	
15 micro	-	8 x 8	8 x 16	24 x 16	24 x 8	
15 normal	-	12 x 12	12 x 24	-	-	
17,1	-	14 x 12	14 x 24	21 x 24	21 x 12	
20	-	12 x 12	12 x 24	18 x 24	18 x 12	
24 micro	-	10 x 8	10 x 16	15 x 16	15 x 8	
24 normal	-	10 x 12	10 x 24	-	-	
Print Speed (cps) in DBCS						
CPI	Super Speed Draft	High Speed Draft	Draft	NLQ	LQ	High Density
6.67	533	355	267	178	133	90
Print Matrix (horizontal x vertical) in DBCS						
CPI	Super Speed Draft	High Speed Draft	Draft	NLQ	LQ	High Density
6.67	8x12	6x24	8x24	12x24	16x24	24x24
Print Density (horizontal x vertical) in DBCS						
CPI	Super Speed Draft	High Speed Draft	Draft	NLQ	LQ	High Density
6.67	60x90	45x180	60x180	90x180	120x180	180x180
Line length (number of characters)						
10 cpi	136		17.1 cpi		233	
12 cpi	163		20 cpi		272	
15 cpi	204		24 cpi		326	

Horizontal Spacing	
10, 12, 15, 16.7, 17.1, 20, 24 & Proportional	
5.6, 6.7, 7.5 in DBCS	
Vertical Spacing	
6, 8, 12 lpi	
3, 4, 6, 8, 12 lines/30 mm	
n/62, n/72, n/180, n/216	
Print Styles	
Draft - Courier - OCR B - Gothic - Prestige - Present - OCR A - Script	
Draft - Courier for DBCS	
Print Attributes	
Sub-superscript, Underline, Overscore, Italics, Emphasized, Double Strike, Shadow, Enlarged, Compressed	
Graphic Resolution (dots per inch)	
horizontal	60, 80, 90, 120, 240, 360
vertical	60, 72, 180, 360
Characters Sets in SBCS	
Standard PC IBM Character Sets	CS1 and CS2
EPSON National Variations	USA, France, Germany, United Kingdom, Denmark-1, Sweden, Italy, Japan, Spain-1, Norway, Denmark-2, Spain-2, Latin America
ANSI National Variations	USA, German, French A, French B, French/Canadian, Dutch, Italian, United Kingdom, Spanish, Danish/Norwegian A, Danish/Norwegian B, Danish/Norwegian C, Danish/Norwegian D, Swedish/Finnish A, Swedish/Finnish B, Swedish/Finnish C, Swedish/Finnish D, Swiss, Yugoslavian, United Kingdom A, Turkish, Greek, Cyrillic
IBM and EPSON Character Sets	USA (CP437), Greek (CP437-G), Slavic (CP437SL), Multilingual (CP850), Greek (CP851), Eastern Europe (CP852), Turkish (CP 853), Cyrillic (CP855), Turkish (CP857), Euro PC Multilingual (CP858), Portugal (CP860), Hebrew (CP862), Canada/France (CP863), Arabic (CP864), Denmark/Norway (CP865), Russian (CP866), Turkish2 (CP867), OCR-A (CP876), OCR-B (CP877), Farsi (CP1098), Latin 2 Windows (CP1250), Cyrillic Windows (CP1251), Latin 1 Windows (CP1252), Greek Windows (CP1253), Turkish Windows (CP1254), Hebrew Windows (CP1255), Arabic Windows (CP1256), Baltic Windows (CP1257), 96 GREEK, GOST, TASS, MAZOWIA, UKRANIAM, KOI8-U, FARSI1, FARSI2
ANSI Character Sets	USA (CP437), Greek (CP437-G), Multilingual (CP850), Greek (CP851), Eastern Europe (CP852), Turkish (CP853), Cyrillic (CP855), Euro PC Multilingual (CP858), Portugal (CP860), Canada/France (CP863), Arabic (CP864), Arabic (CP864E), Denmark/Norway (CP865), Russian (CP866), Turkish2 (CP867), Latin 2 Windows (CP1250), Cyrillic Windows (CP1251), Latin 1 Windows (CP1252), Greek Windows (CP1253), Turkish Windows (CP1254), Hebrew Windows (CP1255), Arabic Windows (CP1256), Baltic Windows (CP1257), MAZOWIA, TURKISH, ROMAN-8, KAMENICKY, CWI, IN2, BULGAR
ISO Character Sets	8859/1 (Latin1), 8859/2 (Latin2), 8859/3 (Latin3), 8859/4 (Latin4), 8859/5 (Latin/Cyrillic), 8859/6 (Latin/Arabic), 8859/7 (Latin/Greek), 8859/8, (Latin/Hebrew), 8859/9 (Latin5). 8859/15 (Latin9)
Characters Sets in DBCS	
GB18030-2000 Standard Chinese Character Set	One, two, and four byte character addressing modes
Bar Codes	
UPC-A, UPC-E, EAN-8, EAN-13, UPC-EAN 2, UPC-EAN 5, Code GP, MSI Plessey, Code BCD, C2/5-3 BAR, Code 39, Code 128, Code 11, Code 93, Codabar, 2/5 Bidirectional, 2/5 Interleaved, 2/5 Industrial, 2/5 Matrix, Postnet	

Emulation in SBCS	
EPSON LQ Series (ESC/P)	
IBM Proprinter XL24/XL24 AGM	
IBM Personal Printer 2391+	
ANSI 3.64	
Emulation in DSBCS	
Epson LQ1600K	
Drivers and Software	
Drivers	Win10 (32/64), Win8 (32/64), Win7 (32/64), WinNT, 98_ME, 2000-WinXP, Win2003 (32/64), WinServer2008 (32/64), Vista
Software	RPMU for Remote Printer Management
Standard Functions	
Automatic print head gap adjustment (AGA)	
Automatic paper path switching via operator panel or S/W commands	
Paper parking	
Plug & Play capability	
Bar Code printing	
Automatic fanfold positioning for tear-off, selectable time-out	
Setting and storage of paper format and print conditions for each paper path in the non volatile memory	
Printing of the macro characters using the Printronix native commands	
Base Configuration	
FRONT1 and FRONT2 PUSH TRACTOR (6 pin)	
Fanfold Width:	76 to 432 mm (3 to 17 inches)
Copies:	1 original + 7 copies
Thickness	Max. 0,635 mm (0.025 inches)
Optional Configuration	
FRONT2 PUSH TRACTOR (6 pin)	
Fanfold Width:	76 to 432 mm (3 to 17 inches)
Copies:	1 original + 7 copies
Thickness	Max. 0,635 mm (0.025 inches)
Physical and Electrical Characteristics	
Interfaces with Automatic interface switching	
Parallel	Centronics Compatible Bi-directional (IEEE-1284) nibble and byte modes - 36 pin Amphenol connector, 7/8 data bits Receive Buffer: max. 128 Kbytes
Serial	RS-232/C - dB 9 connector, Baud Rate: 300 to 115200 bps, 7/8 data bits, DTR & XonXoff flow, Receive Buffer: max. 128 Kbytes
USB	Type B USB 2.0 Compatible Bi-directional - 6 pin connector, 12Mbit/s
LAN	10BASE-T – 100BASE-TX – RJ45 8 pin connector
Reliability	
MTBF	Mean Time between failure: 20,000 hours at 25% DC
MTTR	Mean Time To Repair: 30 minutes
Workload	57000 pages/month (ECMA 132 - 4 hours for 22 days)
Printer Life	5 years
Print Head Life	800 MChrs

Power Supply				
UNIVERSAL	From 90 to 244 VAC			
Power Output	Max. 154 W			
Power Consumption Standby	Model type S809: 30W			
	Model type S809+: <7 W			
Power Consumption Printing	120 W			
Noise Level				
< 54 dBA				
Environment Conditions				
	Temperature	Relative Humidity		
Storage Conditions	-40° to 50° C	10% to 90% RH (not condensing)		
Operating Conditions	10° to 38° C	10% to 90% RH (not condensing)		
Paper Conditions	16° to 24° C	40% to 60% RH (not condensing)		
Physical dimensions (mm/inch) and Weight (Kg/Lbs)				
	Printer only (closed)	Printer Only (front cover open)	Printer on Stand (closed)	Printer on Stand (front cover open)
Width	700/27,55	700/27,55	720/28,34	720/28,34
Height	320/12,59	410/16,14	1020/40,16	1110/43,70
Length "depth"	450/17,71	500/19,68	780/30,71	820/32,28
Weight	19		40	
Basic Printer				
S809, EU	p.n. 260053-001			
S809, AM	p.n. 260053-002			
S809, AP	p.n. 260053-003			
S809, Double Byte	p.n. 260054-001			
Consumables				
1 x Black ribbon cartridge (25 million chs.)	p.n. 260059-001			
6 x Black ribbon cartridge (25 million chs.)	p.n. 260059-002			
Options				
Additional 6 pin Front2 Push Tractor	p.n. 260056-001			
Three Level Floor Open Pedestal	p.n. 260058-001			
Standards				
IEC 60950-1:2005, EN 60950-1:2005, EN55022, CISPR22, EN55024, EN61000-3-2 , EN61000-3-3, EN27779				

Customer Support

Printronix Customer Support Center

IMPORTANT

Please have the following information available prior to calling the Printronix Customer Support Center:

- Model number
- Serial number (located on the back of the printer)
- Installed options (i.e., interface and host type if applicable to the problem)
- Configuration printout:

Press the ON LINE key to take the printer OFF LINE		
Press the PROGRAM key	PRINT OUT? NO	Is displayed
Press the → key	PRINT OUT? YES	The PROGRAM SETUP PRINTOUT is printed
Press the ↓ key until	PRINT STATS? NO	Is displayed
Press the → key	PRINT OUT? YES	The USAGE STATISTICS DATA PRINTOUT is printed
Press the ↓ key until	CONFIG MENU NO	Is displayed
Press the → key to display	CONFIG MENU YES	
Press the ↓ key	PRINT OUT? NO	Is displayed
Press the → key	PRINT OUT? YES	The CONFIGURATION SETUP PRINTOUT is printed
Press the PROGRAM key		
Press the TEAR key and tear off the printout at the perforation		

- Is the problem with a new install or an existing printer?
- Description of the problem (be specific)
- Good and bad samples that clearly show the problem (faxing or emailing these samples may be required)

Americas	(714) 368-2686
Europe, Middle East, and Africa	(31) 24 6489 311
Asia Pacific	(65) 6548 4114
China	(86) 800-999-6836

<http://www.printronix.com/support.aspx>

Printronix Supplies Department

Contact the Printronix Supplies Department for genuine Printronix supplies.

Americas	(800) 733-1900
Europe, Middle East, and Africa	(33) 1 46 25 19 07
Asia Pacific	(65) 6548 4100
China	(86) 400-886-5598

<http://www.primtronix.com/supplies-parts.aspx>

Corporate Offices

Printronix, LLC.
6440 Oak Canyon Rd, Suite 200
Irvine, CA 92618
U.S.A.
Phone: (714) 368-2300
Fax: (714) 368-2600

Printronix Inc.
c/o Printronix Nederland BV
Bijsterhuizen 11-38
6546 AS Nijmegen
The Netherlands
Phone: (31) 24 6489489
Fax: (31) 24 6489499

Printronix Schweiz GmbH
3Changi Business Park Vista
#04-05 AkzoNobelHouse
Singapore 486051
Phone: (65) 6548 4100
Fax: (65) 6548 4111

Printronix Commercial (Shanghai) Co. Ltd
Room 903, 9thFloor
No. 199, North Xizang Road
200070 Shanghai P.R. China
Phone: (86) 400 886 5598
Fax: (8621) 61171256

Printronix India PvtLtd
B-808/809, BSEL Tech Park 8thFloor, Sector 30A
VashaiNaviMumbai 400705 India
Toll Free No.: 1800 102 7896 Fax: (9211) 4158 5555

Visit the Printronix web site at www.printronix.com

SPECIFICATIONS ARE SUBJECT TO CHANGE WITHOUT NOTICE.
This manual refers to various company and products by their trade names.
In most of the cases, these designations are claimed as trademarks or
registered trademarks by their respective companies.

Copyright 2019 PRINTRONIX s.r.l. - Printed in Italy

260066-001B